

3500/20 RACK INTERFACE MODULE

OPERATION AND MAINTENANCE MANUAL

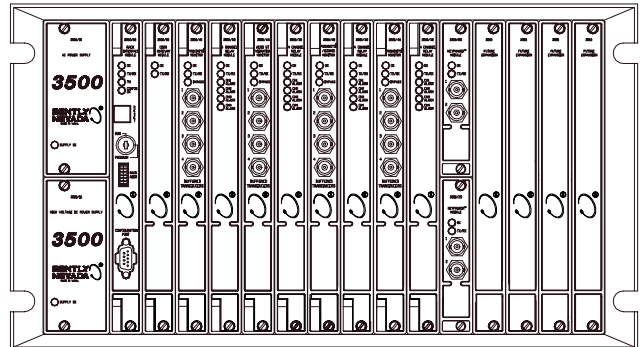

**Copyright © 2000 Bently Nevada Corporation
All Rights Reserved.**

The information contained in this document is subject to change without notice.

The following are trademarks of Bently Nevada Corporation in the United States and other countries:

Actionable Information™, Actionable Information to the Right People at The Right Time™, ADRE®, Bently Nevada®, CableLoc™, Data Manager®, Decision Support™, DemoNet™, Dynamic Data Manager®, Dynamic Transmitter™, Engineer Assist™, FieldMonitor™, FluidLoc™, FlexiTAM™, FlexiTAM™, Helping you Protect and Manage All Your Machinery®, HydroVU™, Key Ø®, Keyphasor®, Machine Condition Manager™ 2000, MachineLibrary™, MicroPROX®, Move Data, Not People™, Move Information, Not Data™, Performance Manager™, PROXPAC®, Proximitor®, REBAM®, Seismoprobe®, System 1™, TDIXconnX™, Tecknowledgy™, TipLoc™, TorXimitor®, Transient Data Manager®, Trendmaster®, TrimLoc™, VAM™, Velomitor®, Xlerometer™

The *Bently Nevada Corporation Orbit Design* is a trademark of Bently Nevada Corporation in the United States and other countries.

The following ways of contacting Bently Nevada Corporation are provided for those times when you cannot contact your local Bently Nevada representative:

Mailing Address	1631 Bently Parkway South Minden, NV 89423 USA
Telephone	1 775 782 3611 1 800 227 5514
Fax	1 775 782 9259
Internet	www.bently.com

Additional Information

NOTICE:

This manual does not contain all the information required to operate and maintain the Rack Interface Module. Refer to the following manuals for other required information.

3500 Monitoring System Rack Installation and Maintenance Manual (129766-01)

- general description of a standard system
- general description of a Triple Modular redundant (TMR) system
- instructions for installing and removing the module from a 3500 rack
- drawings for all cables used in the 3500 Monitoring System

3500 Monitoring System Rack Configuration and Utilities Guide (129777-01)

- guidelines for using the 3500 Rack Configuration software for setting the operating parameters of the module
- guidelines for using the 3500 test utilities to verify that the input and output terminals on the module are operating properly

3500 Monitoring System Computer Hardware and Software Manual (128158-01)

- instructions for connecting the rack to 3500 host computer
- procedures for verifying communication
- procedures for installing software
- guidelines for using Data Acquisition / DDE Server and Operator Display Software
- procedures and diagrams for setting up network and remote communications

3500 Field Wiring Diagram Package (130432-01)

- diagrams that show how to hook up a particular transducer
- lists of recommended wiring

Contents

1	Receiving and Handling Instructions	1
1.1	Receiving Inspection	1
1.2	Handling and Storing Considerations	1
1.3	Disposal Statement	1
2	General Information.....	2
2.1	Triple Modular Redundant (TMR) Description	3
2.2	Statuses	3
2.3	LED Descriptions.....	5
3	Configuration Information.....	6
3.1	Software Configuration Options.....	6
3.1.1	Rack Interface Module Configuration Considerations.....	6
3.1.2	Rack Interface Module Configuration	6
3.1.3	Security Options Configuration	10
3.2	Switches.....	11
3.2.1	Software Switches.....	12
3.2.2	Hardware Switches.....	13
4	I/O Module Description.....	15
4.1	Rack Interface Input/Output (I/O) Modules.....	16
4.1.1	Connecting a Rack Interface I/O Module to a Host Computer	18
4.1.2	Daisy Chaining Rack Interface I/O Modules	24
4.1.3	Wiring Euro Style Connectors	25
4.1.4	Cable Pin Outs	26
4.2	Data Manager I/O Modules.....	32
4.2.1	Cable Pin Outs	33
5	Maintenance	37
5.1	RIM Host Port Test Utility	37
5.2	Performing Firmware Upgrades.....	37
5.2.1	Installation Procedure.....	37
5.3	Real-Time Clock Replacement.....	40
6	Troubleshooting.....	42
6.1	Verification	42
6.2	LED Fault Conditions.....	42
6.3	System Event List Messages.....	44
6.4	Alarm Event List Messages	56
7	Ordering Information	58
8	Specifications	62

1 Receiving and Handling Instructions

1.1 Receiving Inspection

Visually inspect the module for obvious shipping damage. If shipping damage is apparent, file a claim with the carrier and submit a copy to Bently Nevada Corporation.

1.2 Handling and Storing Considerations

Circuit boards contain devices that are susceptible to damage when exposed to electrostatic charges. Damage caused by obvious mishandling of the board will void the warranty. To avoid damage, observe the following precautions.

Application Alert
Host communication and rack configuration capabilities will be lost when this module is removed from the rack.

- Do not discharge static electricity onto the circuit board. Avoid tools or procedures that would subject the circuit board to static damage. Some possible causes include ungrounded soldering irons, nonconductive plastics, and similar materials.
- Personnel must be grounded with a suitable grounding strap (such as 3M Velostat No. 2060) before handling or maintaining a printed circuit board.
- Transport and store circuit boards in electrically conductive bags or foil.
- Use extra caution during dry weather. Relative humidity less than 30% tends to multiply the accumulation of static charges on any surface.
- When performed properly, this module may be installed into or removed from the rack while power is applied to the rack. Refer to the Rack Installation and Maintenance Manual (part number 129766-01) for the proper procedure.

1.3 Disposal Statement

Customers and third parties that are in control of product at the end of its life or at the end of its use are solely responsible for proper disposal of product. No person, firm, corporation, association or agency that is in control of product shall dispose of it in a manner that is in violation of United States state laws, United States federal laws, or any applicable international law. Bently Nevada Corporation is not responsible for disposal of product at the end of its life or at the end of its use.

2 General Information

The Rack Interface Module (RIM) is the primary interface into the 3500 rack. It supports a Bently Nevada proprietary protocol used to configure the rack and retrieve machinery information. The RIM must be located in slot 1 of the rack (next to the power supplies). The RIM provides the connections needed to support current Bently Nevada Communications Processors (Transient Data Interface External (TDIX) and Dynamic Data Interface External (DDIX)). Although the RIM does provide certain functions common to the entire rack, the RIM is not part of the critical monitoring path. The RIM's operation (or non-operation) has no effect on the proper, normal operation of the overall monitoring system.

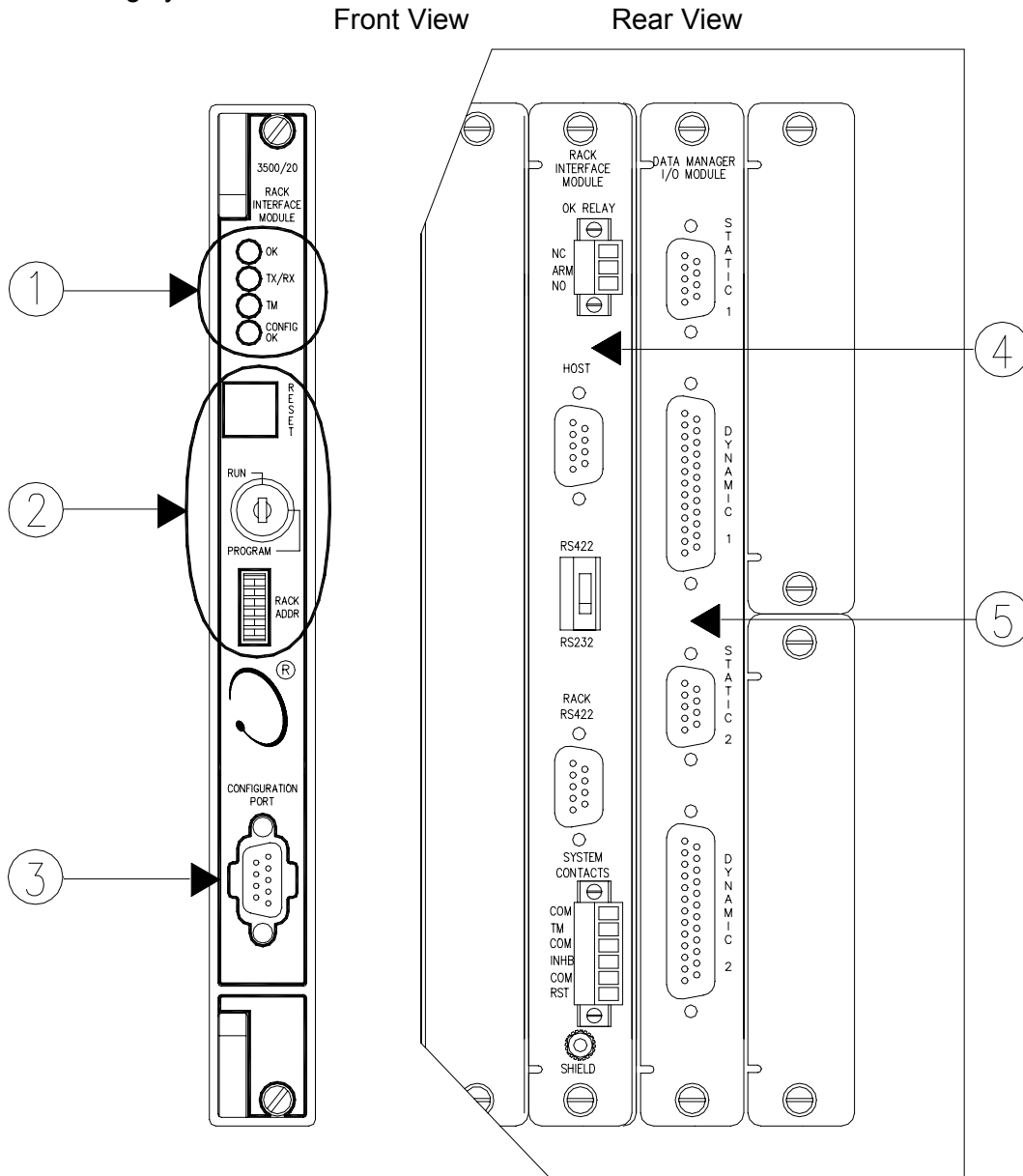

- 1) **LEDs:** Indicate the operating status of the module (See section 2.3)
- 2) **Hardware Switches:** (See section 3.2.2)

- 3) **Configuration Port:** Configure or retrieve machinery data from only this rack using RS-232 protocol.
- 4) **Rack Interface I/O Module:** Daisy chain or configure racks using RS-232 and RS-422 protocol (See section 4.1)
- 5) **Data Manager I/O Module:** Connect two Bently Nevada Communication Processors to the 3500 rack. (See section 4.2)

RIM Features

Contacts

- Rack Reset
- Trip Multiply
- Alarm Inhibit
- OK Relay

Security

- Password
- Key Switch

Communications Ports

- Front Panel Configuration Port
- Rear Panel Host Port
- Rear Panel Rack RS-422 Port
- Data Manager Ports

Event Lists

- Alarm Event List
- System Event List

2.1 Triple Modular Redundant (TMR) Description

For TMR applications, the 3500 system requires a TMR version of the RIM. In addition to all the standard RIM functions, the TMR RIM also performs "monitor channel comparison." The 3500 TMR configuration executes monitoring voting using the setup specified in the monitor options. Using this method the TMR RIM continually compares a specified output of 3 redundant monitors. If the TMR RIM detects that the information from one of those monitors is no longer equivalent (within a configured percent) to the remaining two, it will flag the monitor as being in error and place an event in the System Event List.

2.2 Statuses

The Rack Interface Module returns both module and channel statuses. This section describes the available statuses and where they can be found.

Module Status

OK

This indicates if the Rack Interface Module is functioning correctly. A not OK status is returned under any of the following conditions:

- Hardware Failure in the module
- Communication Failure with any module
- If any of the following security options have been configured and their conditions met:

Rack Address is changed while the RIM is in Run Mode.

A module was inserted into or removed from the rack.
The Key Switch was changed from Run to Program Mode.

- Node Voltage Failure
- OK Relay coil check Failed

If the Module OK status goes not OK then the system OK Relay on the Rack Interface I/O Module will be driven not OK.

Configuration Fault

This indicates if the Rack Interface Module configuration is invalid.

Channel Status

OK

This indicates whether or not a fault has been detected on the channel or within the module. If the Channel OK status goes not OK then the system OK Relay on the Rack Interface I/O Module will be driven not OK.

The following table shows where the statuses can be found.

Statuses	Communication Gateway Module	Rack Configuration Software	Operator Display Software
Module OK	X	X	
Module Configuration Fault		X	
Channel OK	X	X	

2.3 LED Descriptions

The LEDs on the front panel of the Rack Interface Module indicate the operating status of the module as shown in the following figure. Refer to Section 6.2 for all of the available LED conditions.

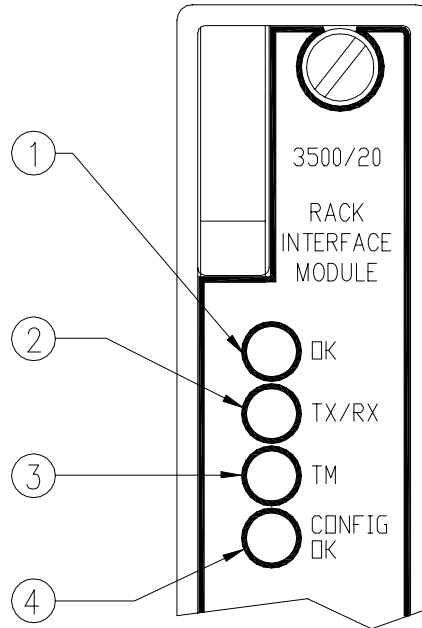

- 1) **OK:** Indicates that the Rack Interface Module and the I/O modules are operating correctly.
- 2) **TX/RX:** Flashes at the rate that messages are sent.
- 3) **TM:** Indicates whether the rack is in the Trip Multiply mode.
- 4) **Config OK:** Indicates that Any module in the rack is unconfigured or has a configuration error or the stored configuration of the Rack Interface Module does not match the physical configuration of the rack or a security option condition was not met.

3 Configuration Information

This section describes how the Rack Interface Module is configured using the Rack Configuration Software. It also describes any configuration considerations associated with this module. Refer to the 3500 Monitoring System Rack Configuration and Utilities Guide and the Rack Configuration Software for the details on how to operate the software.

3.1 Software Configuration Options

This section shows the configuration screens of the Rack Configuration Software that are associated with the Rack Interface Module and discusses the configuration considerations. It will show a copy of the software screen and will explain the options that are available.

3.1.1 Rack Interface Module Configuration Considerations

The Rear Port I/O option and the Power Supply option specified on the Rack Interface Module option screen must match the physical components of the system. If a configuration mismatch is found, the rack will not accept the downloaded configuration.

3.1.2 Rack Interface Module Configuration

This section describes the options available on the Rack Interface Module configuration screen.

Rack Interface Module (RIM)

Config ID:

Rear Port I/O Option

Internal Modem
 RS232/422-Ext Modem

External Modem

None

Initialization String:

Byte Timeout: 20

Front Port External Modem

None

Initialization String:

Byte Timeout: 20

Dynamic Signal Option

Slots 2-7

Rack Mounting Option

Panel Mounted
 Rack Mounted
 Bulkhead Mounted

Power Supply Option

Top: AC High Voltage

Bottom: AC High Voltage

Connect Password:

Configuration Password:

Agency Approval: None

CE Approval

OK Security Options... Cancel Print Form Help

BENTLY NEVADA

Config ID

Contains a unique six-character identifier which is entered when a configuration is downloaded to the 3500 rack.

Rear Port

The port on the Rack Interface I/O Module labelled HOST that is used to connect this 3500 rack to the 3500 host computer or the 3500 rack daisy chained closer to the 3500 host computer.

I/O Option

The two types of Rack Interface I/O Modules that are available for the 3500 Monitoring System are the RS-232/RS-422 I/O Module and Modem I/O Module. The RS-232/RS-422 I/O Module contains a 9-pin host connector which contains either RS-232 or RS-422 level signals, dependent upon the position of the I/O Module switch. The Modem I/O Module has an RJ11 connector and contains an internal modem.

External Modem

The following external modems are directly supported by the Rack Interface Module when configured with an RS-232/RS-422 I/O Module:

- None
- Hayes Ultra 9600
- Hayes Optima 9600
- Motorola FasTalkII 9600
- Custom

Initialization String

The command that sets up and starts the modem. If you select a modem from the list, the default initialization string will be displayed in this field. If you select Custom, enter an initialization string from information found in the modem's documentation.

Byte Timeout

The number of byte times which the communication line must be idle before a communication is considered complete. One byte time is a function of the baud rate selected. The range of values is 3 to 255.

Connect Password

Provides read only access to the 3500 rack. If the password entered in this field does not match the password entered in the Rack Configuration Software "Connect" screen or in the Data Acquisition/DDE Server Software "Setup" screen, no communication with the 3500 rack will be allowed. This password is stored in non-volatile memory in the Rack Interface Module.

Configuration Password

Provides configuration write access to the 3500 rack. If the password entered in this field does not match the password entered in the Rack Configuration Software "Download" screen, the 3500 rack will not accept new configurations. This password is also required to change setpoints in the 3500 rack from the Operator Display Software. This password is stored in non-volatile memory in the Rack Interface Module.

Front Port

The port on the front of the Rack Interface Module labelled CONFIGURATION PORT that is primarily used to configure the 3500 rack with a personal computer. This port may also be used to retrieve machinery data for display using the Data Acquisition/DDE Server Software and the Operator Display Software. This port supports RS-232 only and provides access to only one rack.

External Modem

The following external modems are directly supported by the Rack Interface Module:

- None
- Hayes Ultra 9600
- Hayes Optima 9600
- Motorola FasTalkII 9600
- Custom

Initialization String

The command that sets up and starts the modem. If you select a modem from the list, the default initialization string will be displayed in this field. If you select Custom, enter an initialization string from information found in the modem's documentation.

Byte Timeout

The number of byte times which the communication line must be idle before a communication is considered complete. One byte time is a function of the baud rate selected. The range of values is 3 to 255.

Static Data Considerations

Each static data port can access six monitor slots in the 3500 rack. And each monitor slot in the 3500 rack is limited to 32 PPLs.

Dynamic Signal Option

Identifies which monitors provide dynamic data to the DYNAMIC connectors on the Data Manager I/O Module. This field defines how the 3500 rack will provide machinery data to the Communication Processors (TDIX or DDIX).

The following table shows the different options that are available. Keep the following in mind:

- Dynamic Port 2 is always assigned to slots 8 through 13.
- If a slot contains something other than a monitor, then no data for that slot is returned.
- No data can be returned from the modules installed in slots 14 and 15.

Dynamic Signal Option

Monitors Assigned to Data Manager Ports

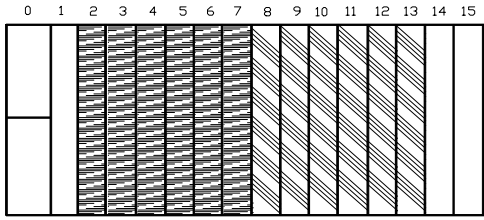
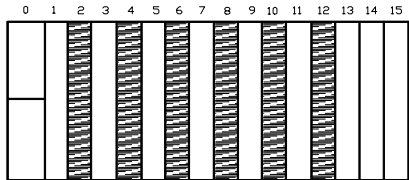
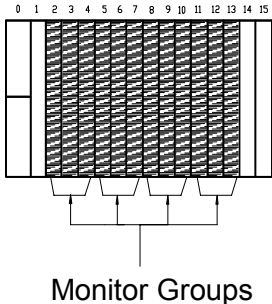
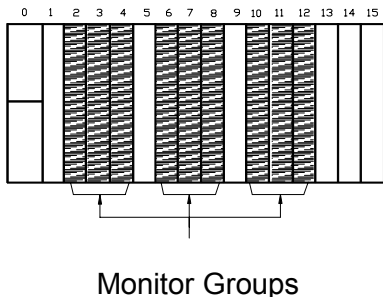
<p>Slots 2-7 assigned to Data Manager Port 1</p> <p>Rack Type: Standard Number of Communication Processors: 2</p> <p>Slots 14 and 15 can not return any data since each TDIX and DDIX can only be connected to a maximum of 24 channels.</p>	
<p>Slots 2, 4, 6, 8, 10, 12 assigned to Data Manager Port 1</p> <p>Rack Type: Standard Number of Communication Processors: 1</p> <p>Use this option when the rack is setup with multiple monitor/relay pairs.</p>	
<p>Slots 2, 5, 8, 11 assigned to Data Manager Port 1</p> <p>Rack Type: TMR with Bussed Relay Number of Communication Processors: 1</p> <p>If a monitor is removed from slots 2, 5, 8 or 11 then no data is returned to the Communication Processor from that monitor group.</p>	
<p>Slots 2, 6, 10 assigned to Data Manager Port 1</p> <p>Rack Type: TMR with Individual Relays Number of Communication Processors: 1</p> <p>If a monitor is removed from slots 2, 6 or 10 then no data is returned to the Communication Processor from that monitor group.</p>	

Legend

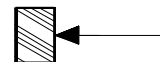
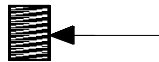

Monitors Assigned to Data Manager Port 1

Monitors Assigned to Data Manager Port 2

Agency Approvals

The following Agency Approvals are available for the 3500 rack:

- None
- CSA-NRTL/C

CE Approval

Select this box if the CE mark is applicable to the rack's installation.

Rack Mounting Option

Select the type of 3500 rack that is installed or is going to be installed. Refer to the 3500 Monitoring System Rack Installation and Maintenance Manual for a description of the various mounting options.

Power Supply

The following power supplies can be installed in the 3500 rack:

<u>Upper Position in Slot</u>	<u>Lower Position in Slot</u>
No Power Supply	No Power Supply
AC High Voltage	AC High Voltage
AC Low Voltage	AC Low Voltage
DC High Voltage	DC High Voltage

3.1.3 Security Options Configuration

This Section describes the options available on the Rack Interface Module Security Option Configuration screen.

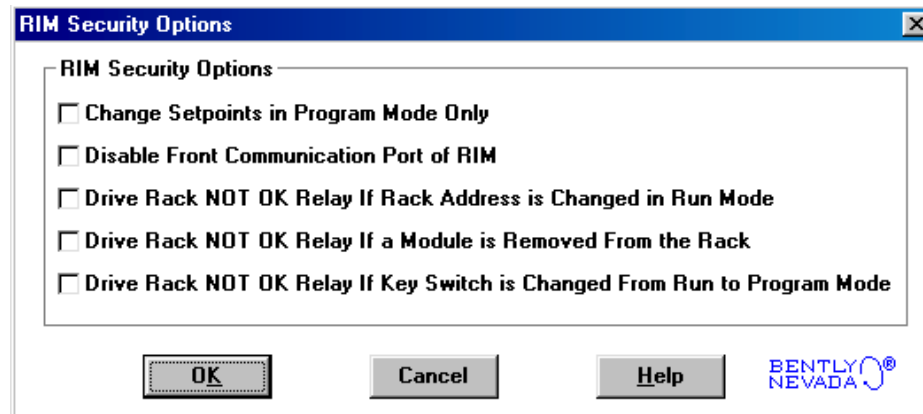

Change Setpoints in Program Mode Only

This will only allow changes to setpoints in any of the monitors if the keylock is in the program mode position. If the key is in the run position, setpoint changes will not be allowed.

Disable Front Communication Port of RIM

This option disables all write functions through the front communication port on the Rack Interface Module when selected. When in this mode the Rear Communication Port is still active.

Drive Rack NOT OK Relay if Rack Address is Changed in Run Mode

With this option selected the NOT OK Relay will go into a NOT OK state if the Rack Address is changed at any time while the key switch is in the run position.

Drive Rack NOT OK Relay if a Module is Removed From the Rack

When selected this option will force the NOT OK Relay into a NOT OK state if any module is removed from its slot in the Rack.

Drive Rack NOT OK Relay if Key Switch is Changed From Run to Program Mode

The Rack NOT OK Relay will go into a NOT OK state any time that the key switch is changed from Run to Program mode when this option is selected.

3.2 Switches

Switches let you control the operation of the 3500 rack and control access to the configuration of the rack. This section lists the software and hardware switches that are available for the Rack Interface Module.

3.2.1 Software Switches

The Rack Interface Module supports one software module switch - Configuration Mode. The switch lets you temporarily inhibit monitor and channel functions. This switch can be set on the **Software Switches** screen under the **Utilities** Option on the main screen of the Rack Configuration Software.

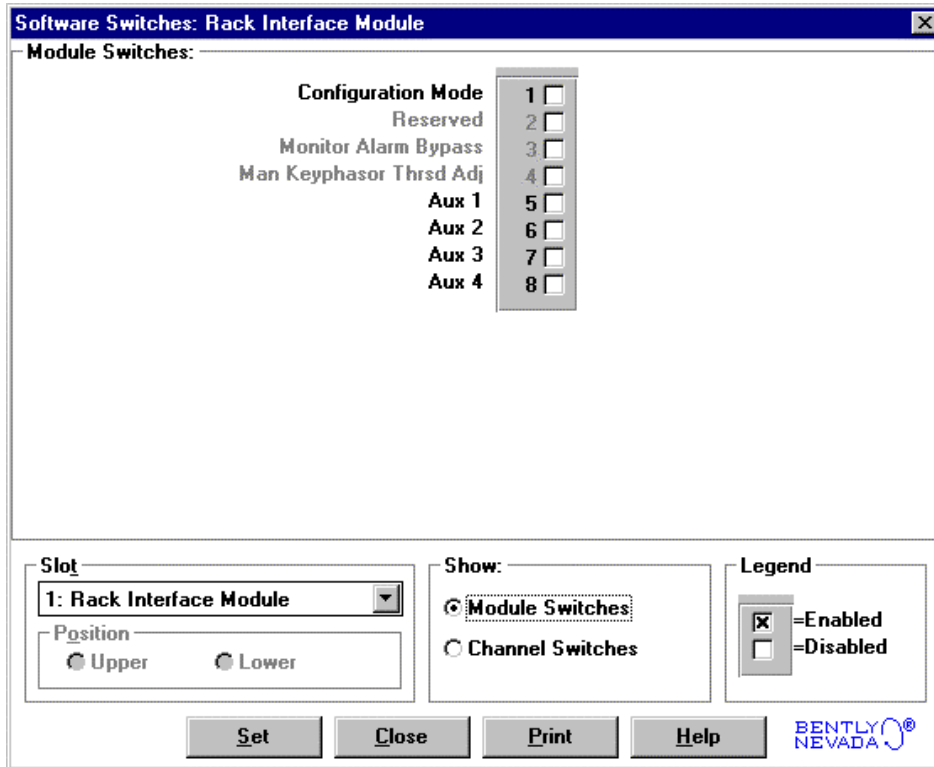

No changes will take effect until the **Set** button is pressed.

Module Switch

Configuration Mode

A switch that allows the rack to be configured. To set the rack in configuration mode, enable (☑) this switch and set the key switch on the front of the Rack Interface Module in the PROGRAM position. When downloading a Rack Interface Module configuration, this switch will automatically be enabled and disabled by the Rack Configuration Software. If the connection to the rack is lost during the configuration process, use this switch to remove the module from Configuration Mode.

The module switch number is used in the Communication Gateway Module.

<u>Module Switch Number</u>	<u>Switch Name</u>
1	Configuration Mode

3.2.2 Hardware Switches

The Rack Interface Module has three hardware switches that are found on the front panel.

Key Switch

The Key Switch is used to prevent unauthorized changes to the configuration settings. When the switch is in the RUN position, the 3500 rack cannot be configured. When the switch is in the PROGRAM position, the 3500 rack can be configured and the rack continues to operate normally. By removing the key, you can lock the Rack Interface Module in the RUN or PROGRAM position.

Rack Reset

Note

An RS-232/RS-422 I/O Module or a Modem I/O Module must be installed for the Rack Reset switch to function correctly.

When the Rack Reset switch is pressed, any monitors in the rack will clear latched alarms and reset Timed OK Channel Defeat indications. If the Configuration LED is blinking at 5 Hz, it will be stopped. This switch performs the same function as the Rack Reset contact on the Rack Interface I/O Module.

Rack Address

The host computer uses the Rack Address to identify 3500 racks that are linked in a daisy chain. Set the rack address by using a 6-position DIP switch which provides for 63 possible addresses. All racks in a daisy chain must have a unique rack address. The following diagram and table show how to select the address 110001 (49 decimal).

LSB - Least Significant Bit

MSB - Most Significant Bit

Note: The white area shows the direction of the switch.

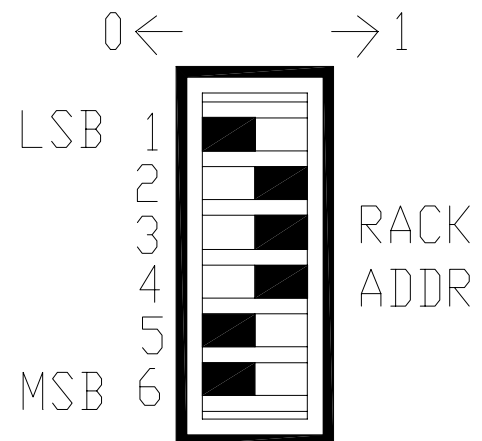

Switch Addresses		Available Rack Address		Switch Addresses	
MSB	LSB	MSB	LSB	MSB	LSB
<u>654321</u>	_____	<u>654321</u>	_____	<u>654321</u>	_____
000000	1*	010110	22	101011	43
000001	1	010111	23	101100	44
000010	2	011000	24	101101	45
000011	3	011001	25	101110	46
000100	4	011010	26	101111	47
000101	5	011011	27	110000	48
000110	6	011100	28	110001	49
000111	7	011101	29	110010	50
001000	8	011110	30	110011	51
001001	9	011111	31	110100	52
001010	10	100000	32	110101	53
001011	11	100001	33	110110	54
001100	12	100010	34	110111	55
001101	13	100011	35	111000	56
001110	14	100100	36	111001	57
001111	15	100101	37	111010	58
010000	16	100110	38	111011	59
010001	17	100111	39	111100	60
010010	18	101000	40	111101	61
010011	19	101001	41	111110	62
010100	20	101010	42	111111	63
010101	21				

* The address 000000 is reserved for the host. Setting the switches to 000000 will select a Rack Address of 1 just as 000001 will.

4 I/O Module Description

The Rack Interface Module uses two I/O module types, the Rack Interface I/O Module and the Data Manager I/O Module. These I/O modules let you connect a 3500 host computer and Communication Processors (TDIX or DDIX) to a 3500 rack and let you daisy chain racks together.

This section describes how to use the connectors on the I/O modules, lists what cables to use, and shows the pin outs of the cables.

Only one Rack Interface I/O Module can be installed at a time behind the Rack Interface Module (in a Rack Mount or a Panel Mount rack) or above the Rack Interface Module (in a Bulkhead rack). See Section 4.1

Also, one Data Manager I/O Module may be installed between the Power Input Modules and the Rack Interface I/O Module (in a Rack Mount or a Panel Mount rack) or above the Power Supplies between the Power Input Modules and the Rack Interface I/O Module (in a Bulkhead rack). See Section 4.2

4.1 Rack Interface Input/Output (I/O) Modules

The two types of Rack Interface I/O Modules that are available for the 3500 Monitoring System are the RS-232/RS-422 I/O Module and the Modem I/O Module. The features below are common to both I/O Modules.

The Rack Interface I/O module must be installed behind the Rack Interface Module (in a Rack Mount or Panel Mount rack) or above the Rack Interface Module (in a Bulkhead rack).

- 1) **OK RELAY:** The OK Relay is normally energized and is used to indicate whether the 3500 Monitoring System is OK.
- 2) **RACK RS-422:** Used to daisy chain to the next 3500 rack. Up to 12 racks can be daisy chained together. Only RS-422 can be used for this connection.
- 3) **EXTERNAL CONTACTS:**
 - Trip Multiply
 - Rack Alarm Inhibit
 - Rack Reset

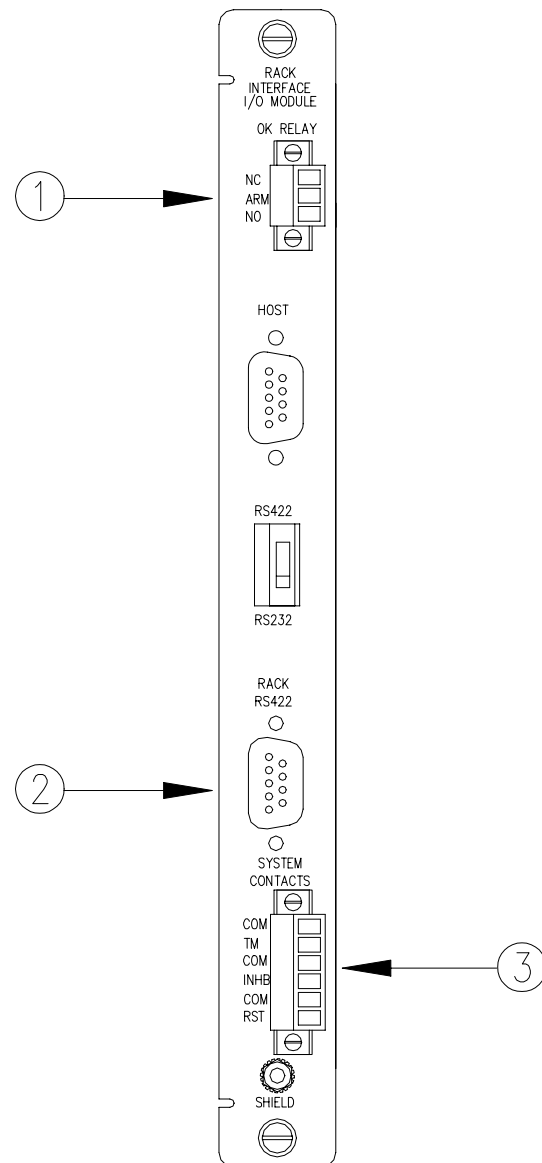

OK RELAY

The following items will cause the OK Relay to go NOT OK:

- Removing the Rack Interface Module from the 3500 rack
- Plugging a module into the 3500 rack (during self-test)
- Transducer going not OK (except Keyphasor)
- Hardware failure within a module
- Configuration Failure
- Slot ID Failure
- Any module in the 3500 rack which has detected a fault
- Communication Failure with any module.
- If any of the following security options have been configured and their conditions met:

Rack Address is changed while the RIM is in Run Mode.

Any module is inserted or removed from the rack.

The Key Switch is changed from Run Mode to Program Mode.

The following diagrams show the different ways the OK Relay can be wired:

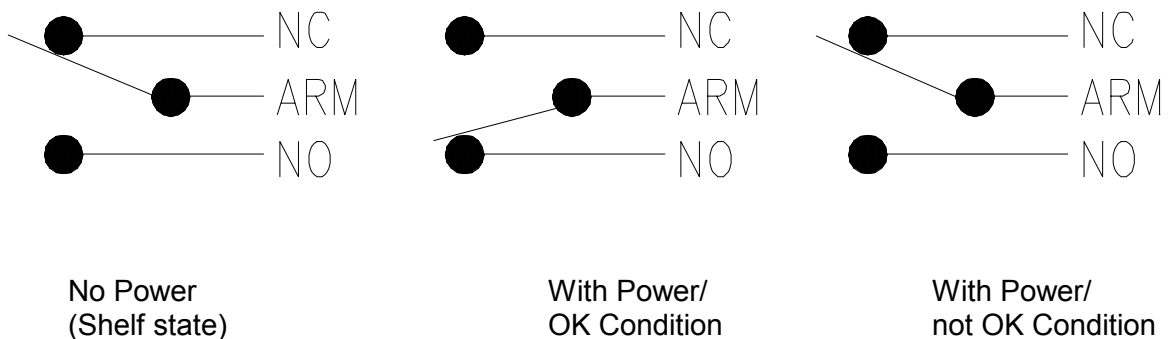
Normally Energized

NO means Normally Open.
 ARM means Armature.
 NC means Normally Closed.

RACK RS-422

Used to daisy chain to the next 3500 rack in the chain. The cable will go between the RACK RS-422 connector on this rack and the HOST connector on the next 3500 rack. Only RS-422 can be used for this connection. Refer to Section 4.1.2

EXTERNAL CONTACTS

These require dry contact inputs. To enable a specific function, short the desired contact to a system common (COM).

Trip Multiply (TM)

Used to signal when the rack should be in Trip Multiply.

Rack Alarm Inhibit (INHB)

Used to prevent an alarm from being declared on any monitor or relay in the 3500 rack. This is typically used when performing maintenance functions.

Rack Reset (RST)

Used to signal when the modules in the 3500 rack are to be reset. This contact has the same function as the Rack Reset switch on the front panel of the Rack Interface Module.

4.1.1 Connecting a Rack Interface I/O Module to a Host Computer

The 3500 rack can use two types of Rack Interface I/O Modules which let you connect a host computer to a rack in a number of ways.

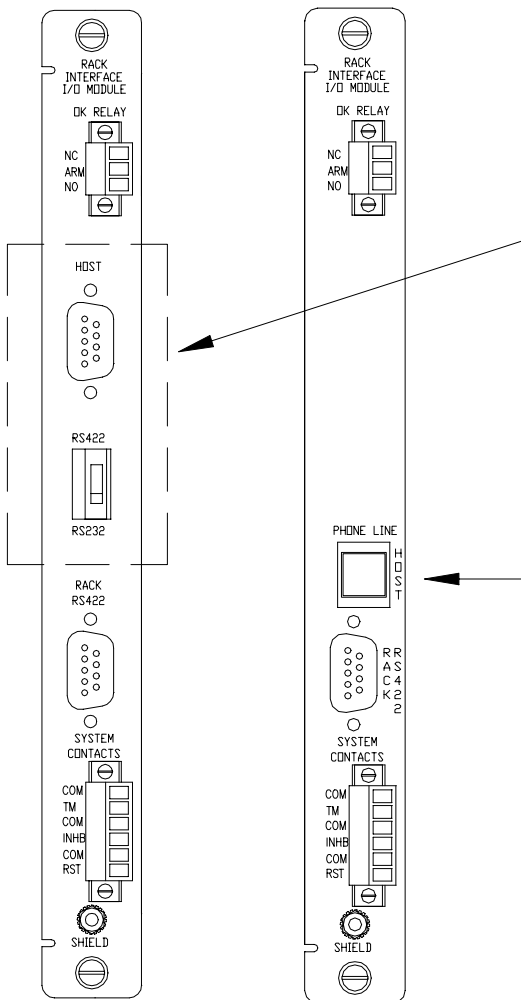

RS-232/RS-422 HOST Connector

Connect to the host computer using RS-232, RS-422 (with a converter) or external Modem. Also used to connect to the previous rack in the daisy chain using RS-422 ONLY.

Use the RS-232/RS-422 switch to select whether the HOST connector uses RS-232 or RS-422 protocol.

Internal Modem Connector

Connect to the host computer using a RJ11 compatible modular plug to link into the phone system.

Note

RS-232 signals are referenced to earth ground. This reference through the RS-232 cable has the potential of causing grounding problems. To avoid grounding problems when using RS-232 communications use serial data isolator P/N 02200633

4.1.1.1 Connecting a Rack Interface I/O Module to a Host Computer via RS-232

The communication rate is limited by the baud rate selected between the 3500 host computer and the first Rack Interface Module. The switch on the Rack Interface I/O Module connected to the 3500 host computer must be in the RS-232 position.

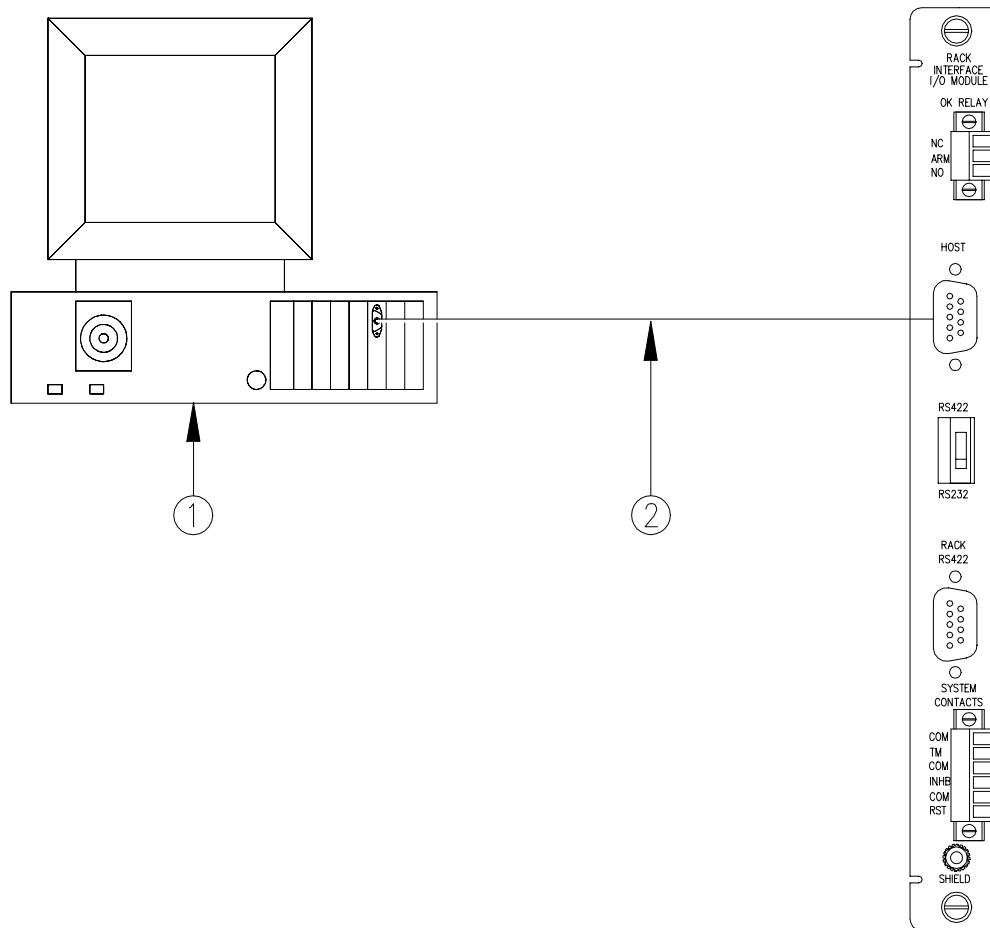

- 1) Host Computer
- 2) Cable 130118-XXXX-XX is available in various lengths up to 30 meters (100 ft).

Refer to Section 7 for the specific options of the cable listed above.

4.1.1.2 Additional Information for Connecting a Rack Interface I/O Module to a Host Computer via RS-232 in Intrinsically Safe Application

To avoid ground loops, the system must provide a single point ground. In Intrinsically Safe applications the 3500 Rack is floated and referenced to an intrinsically safe ground instead of earth ground. RS-232 communications are referenced to earth ground, and therefore to keep the rack isolated from earth ground, a serial data isolator must be used.

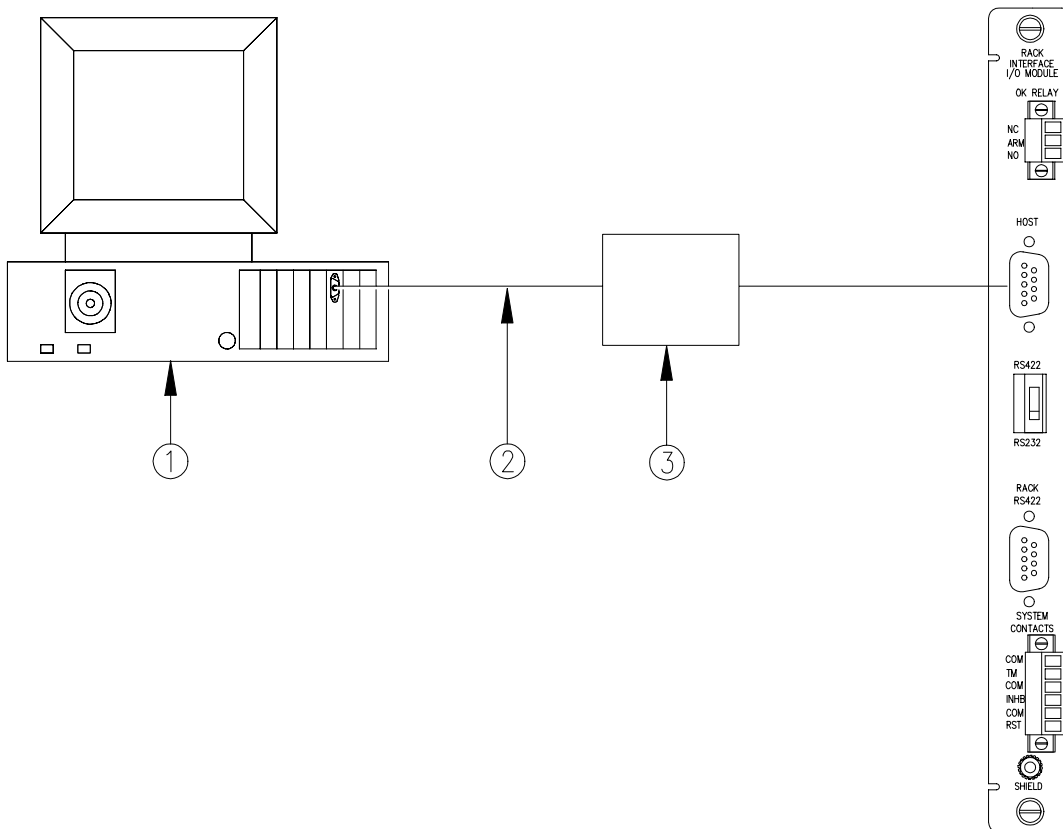

- 1) Host Computer
- 2) Cable 130118-XXXX-XX is available in various lengths up to 30 meters (100 ft).
- 3) Serial Data Isolator P/N 02200633

Refer to Section 7 for the specific options of the cable listed above.

4.1.1.3 Connecting a Rack Interface I/O Module to a Host Computer via RS-422

The communication rate is limited by the baud rate selected between the 3500 host computer and the first Rack Interface Module. The switch on the Rack Interface I/O Module connected to the 3500 host computer must be in the RS-422 position.

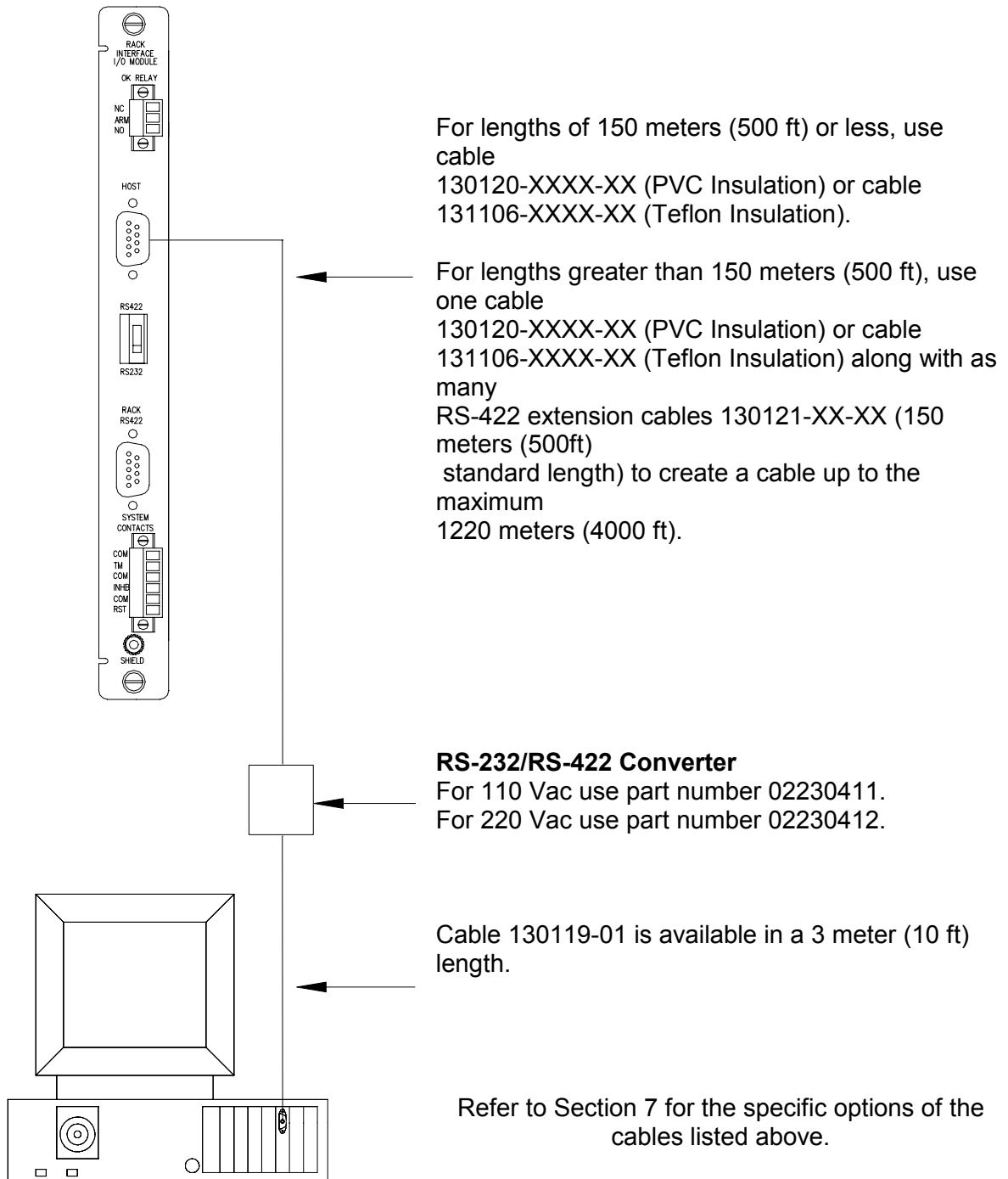

4.1.1.4 Connecting a Rack Interface I/O Module to a Host Computer via an External Modem

The communication rate is limited by the baud rate selected between the 3500 host computer and the first Rack Interface I/O Module. The switch on the Rack Interface I/O Module connected to the modem must be in the RS-232 position.

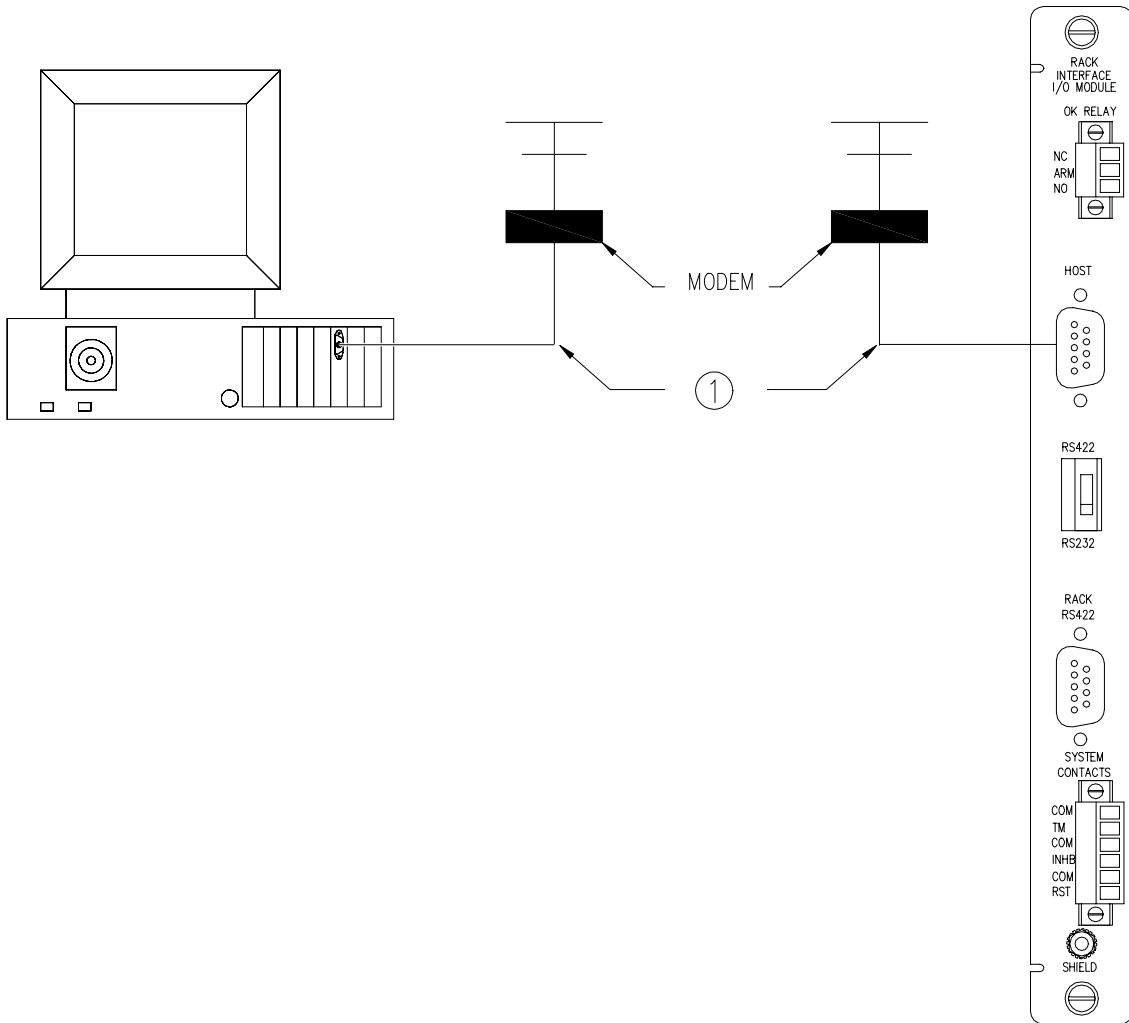

1) Cable 02290860 is available in 3 meter (10ft) length.

Refer to Section 7 for the specific options of the cable listed above.

4.1.1.5 Connecting a Rack Interface I/O Module to a Host Computer via an Internal Modem

The communication rate is limited by the baud rate selected between the host computer and the first Rack Interface I/O Module.

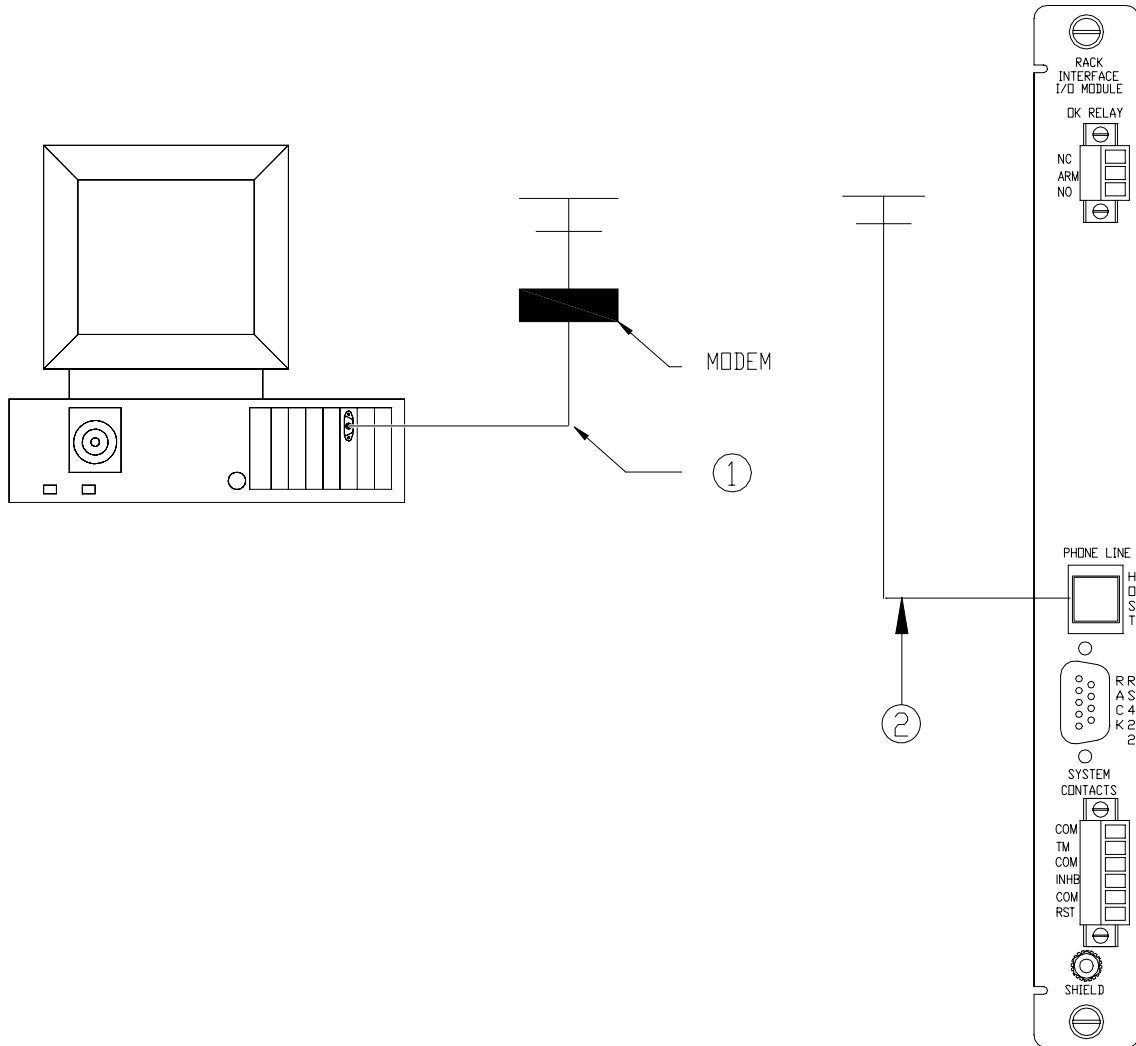

- 1) Cable 02290860 is available in 3 meter (10ft) length.
- 2) Phone Line

Refer to Section 7 for the specific options of the cables listed above.

4.1.2 Daisy Chaining Rack Interface I/O Modules

This section shows how to daisy chain Rack Interface I/O Modules together.

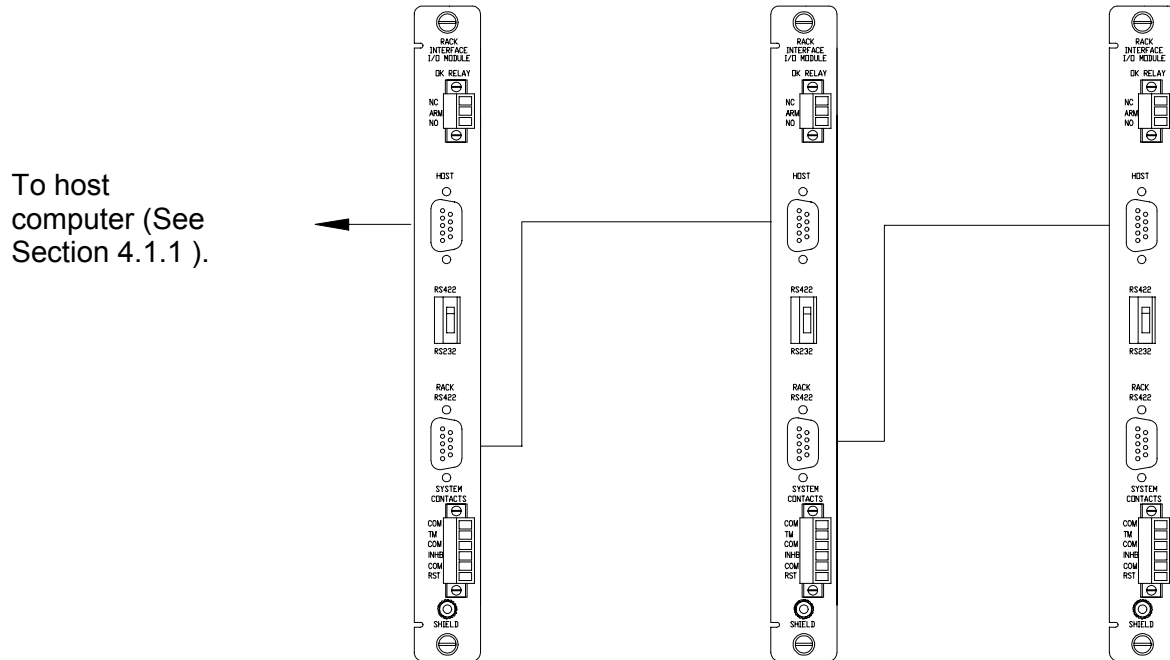

Take note of the following items when daisy chaining Rack Interface I/O Modules:

- Use the HOST port to connect to the host computer or to the rack in the daisy chain that is closer to the host computer.
- Use the RACK RS-422 port to connect to the rack that is farther from the host computer.
- Use the following cables for the connection between the racks in the daisy chain:
 - For lengths of 150 meters (500 ft) or less, use cable 130122-XXXX-XX (PVC Insulation) or cable 131107-XXXX-XX (Teflon Insulation).
 - For lengths greater than 150 meters (500 ft), use one cable 130122-XXXX (PVC Insulation) or cable 131107-XXXX-XX (Teflon Insulation) along with as many RS-422 extension cables 130121-XX-XX (150 meters (500 ft) standard length) to create a cable up to 1220 meters (4000 ft) in length.

Refer to Section 7 for the specific options of the cables listed above.

4.1.3 Wiring Euro Style Connectors

To remove a terminal block from its base, loosen the screws attaching the terminal block to the base and then grip the block firmly and pull. Do not pull the block out by its wires because this could loosen or damage the wires or connector.

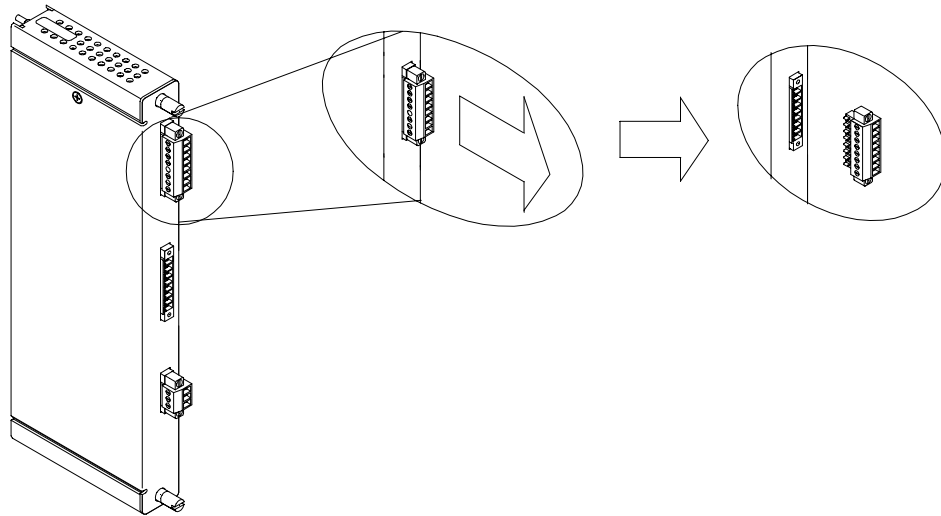

Typical I/O module

Refer to the 3500 Field Wiring Diagram Package for the recommended wiring. Also, do not remove more than 6 mm (0.25 inches) of insulation from the wires.

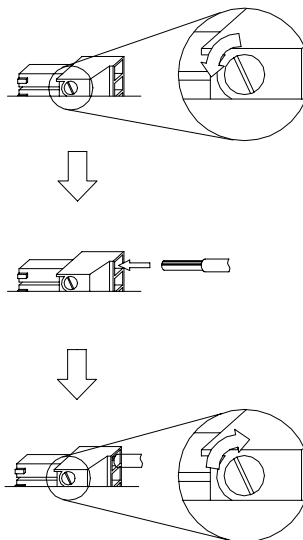

4.1.4 Cable Pin Outs

Cable Number 02290860
 Host Computer (or Rack Interface Module) to External Modem Cable

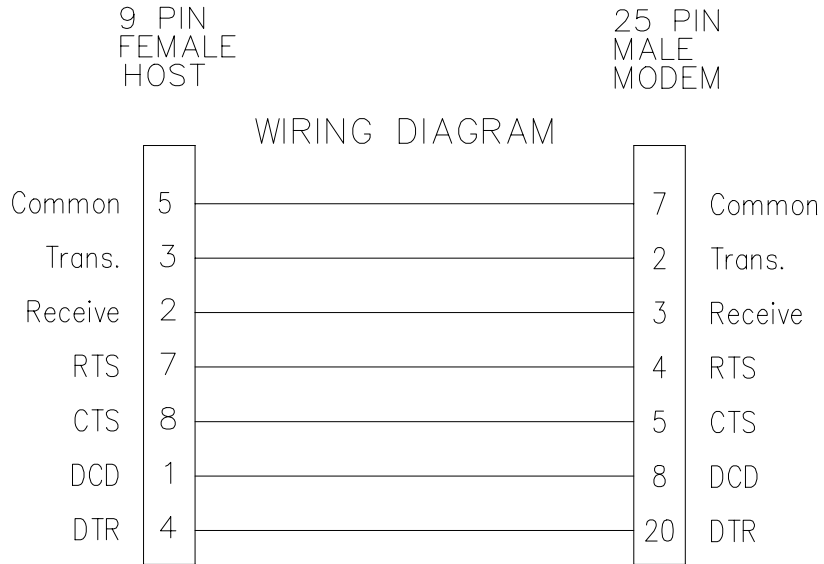

Cable Number 130118-XXXX-XX
 Host Computer to 3500 Rack RS-232 Interface Cable

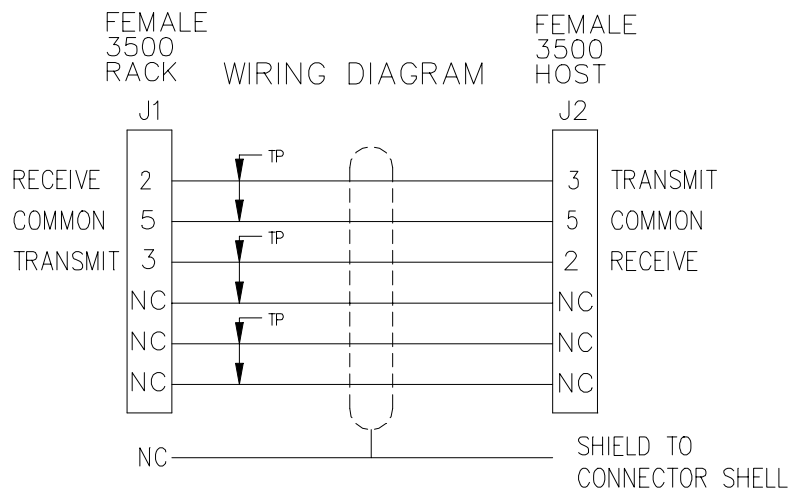

Cable Number 132632-XXXX-XX
Host Computer to 3500 Rack Cable RS-422 PVC

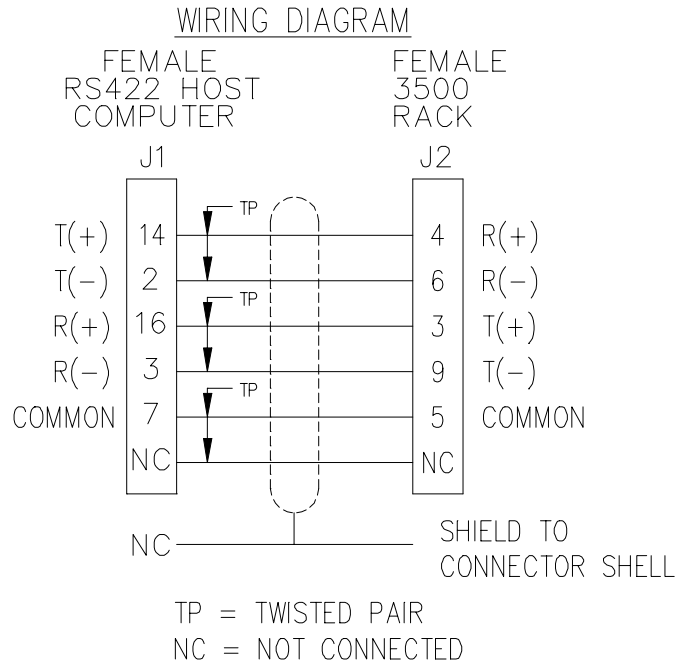

Cable Number 132633-XXXX-XX
Host Computer to 3500 Rack Cable RS-422 Teflon

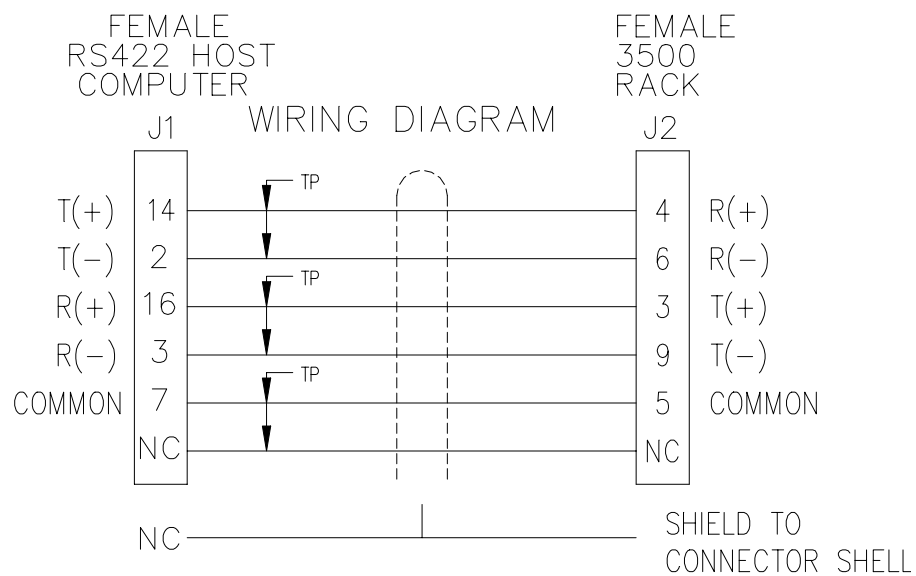

**Cable Number 130119-01
Host Computer to RS-232/422 Converter Cable**

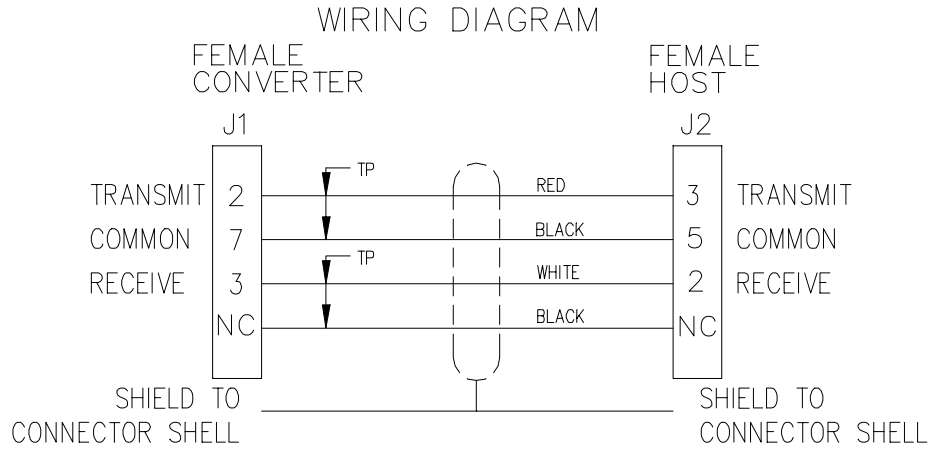

**Cable Number 130120-XXXX-XX
RS-232/422 Converter to 3500 Rack Cable (RS-422) - PVC Insulation**

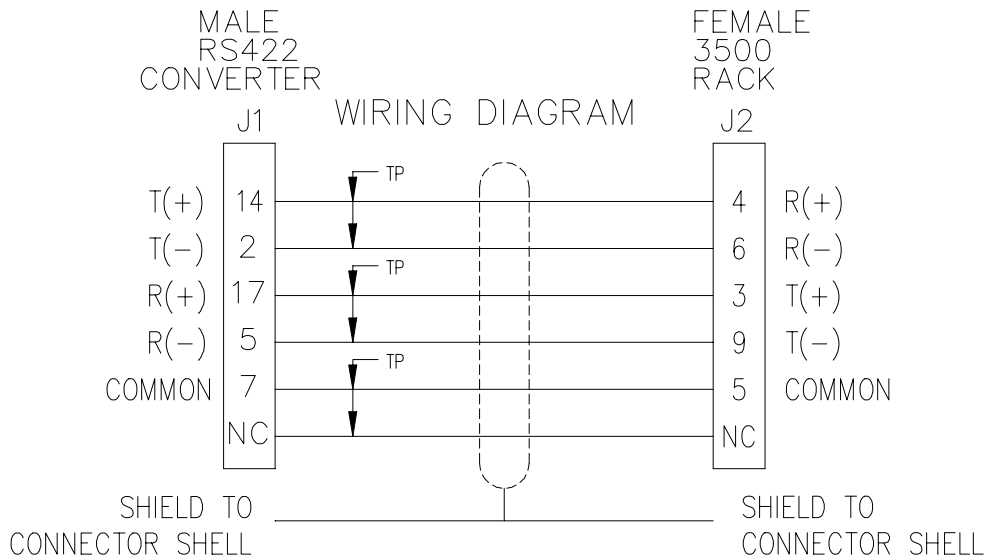

Cable Number 130121-XX-XX
RS-422 Extension Cable

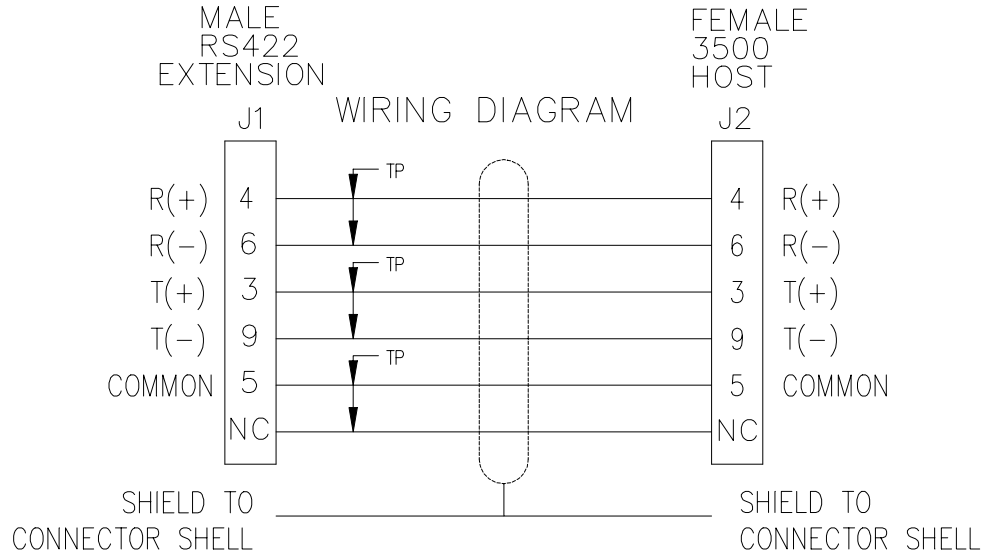

Cable Number 130122-XXXX-XX
RS-422 3500 Rack to 3500 Rack Cable - PVC Insulation

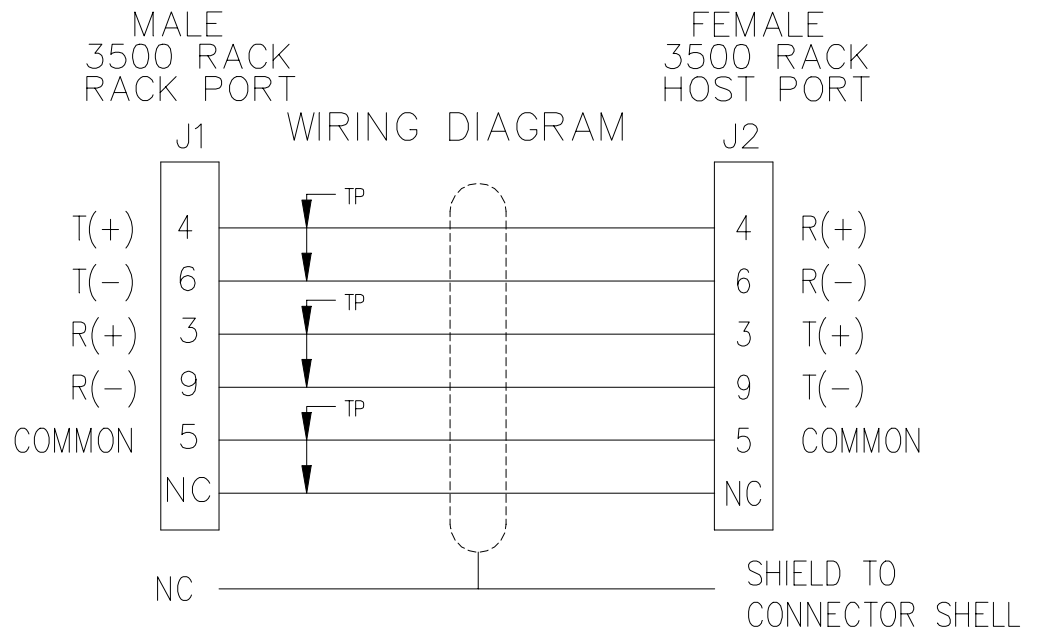

Cable Number 131106-XXXX-XX
RS-232/422 Converter to 3500 Rack Cable (RS-422) - Teflon Insulation

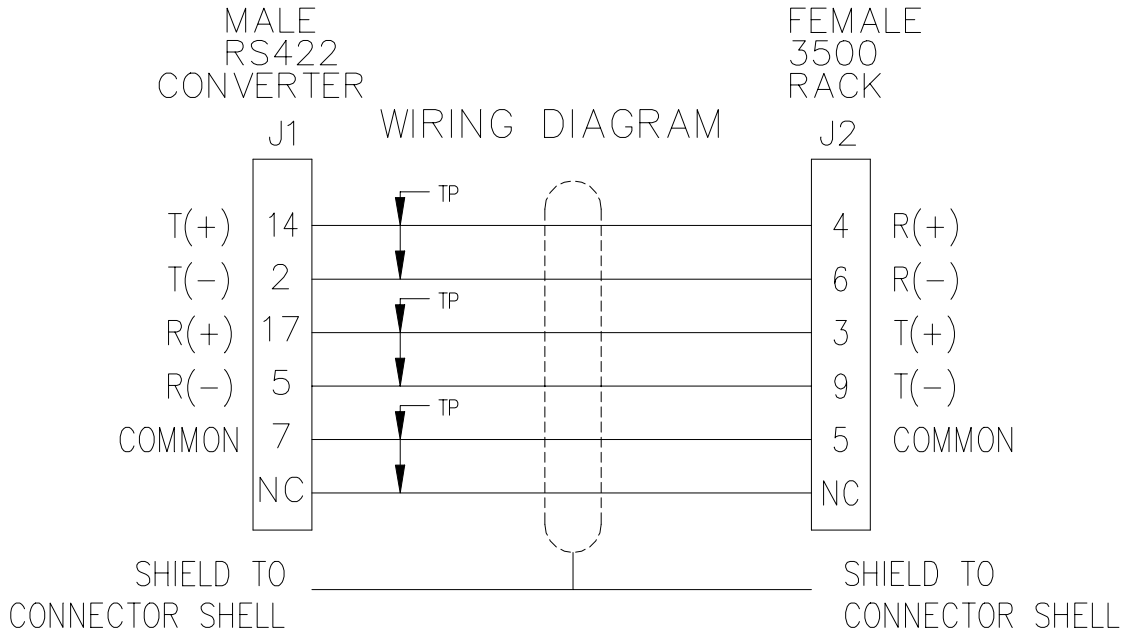

Cable Number 131107-XXXX-XX
RS-422 3500 Rack to 3500 Rack Cable - Teflon Insulation

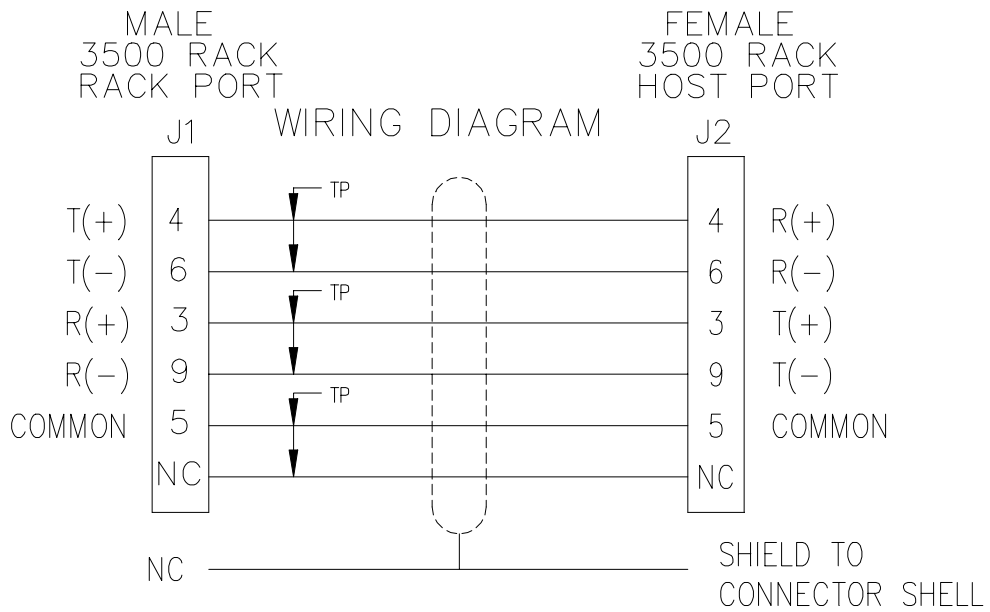

Cable Number 145164-XXXX-XX
Integrated PC Display to 3500 Rack Cable, RS-422, PVC Insulated

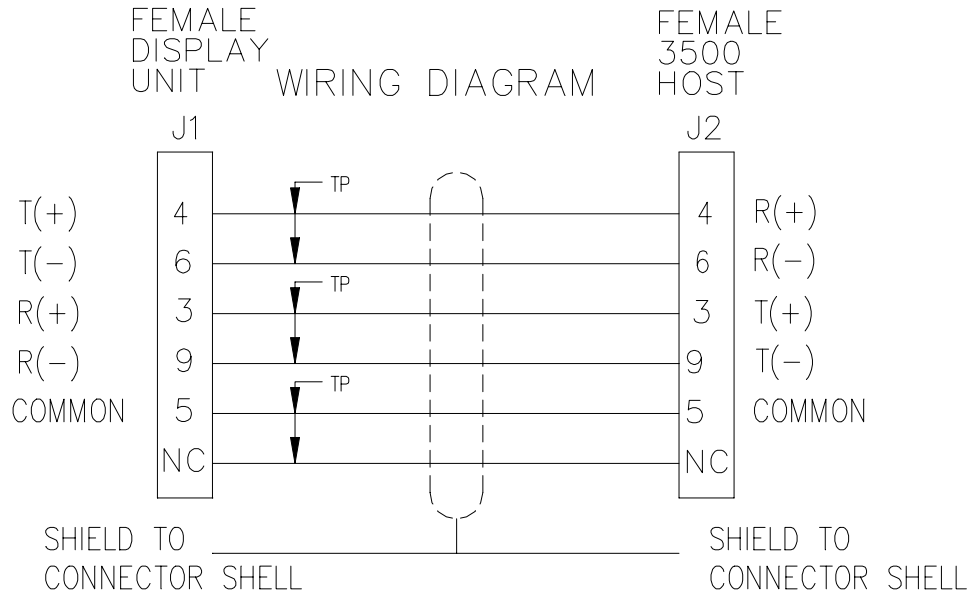

Cable Number 145165-XXXX-XX
Integrated PC Display to 3500 Rack Cable, RS-422, Teflon Insulated

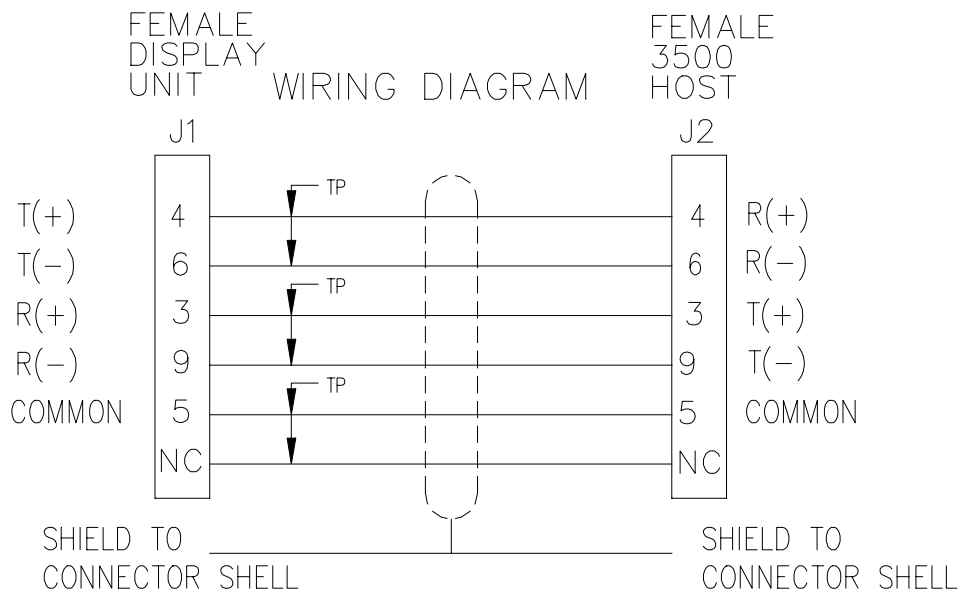

4.2 Data Manager I/O Modules

The Data Manager I/O Module must be installed behind the Power Supplies between the Power Input Modules and the Rack Interface I/O Module (in a Rack Mount or Panel Mount rack) or above the Power Supplies between the Power Input Modules and the Rack Interface I/O Module (in a Bulkhead rack). The function of the Data Manager I/O module is to connect the 3500 rack to TDIX or DDIX Communication Processors. Each port can connect up to 24 channels, from the 3500 rack to the Communication Processor. Refer to the table on page 9 for the different options that are available.

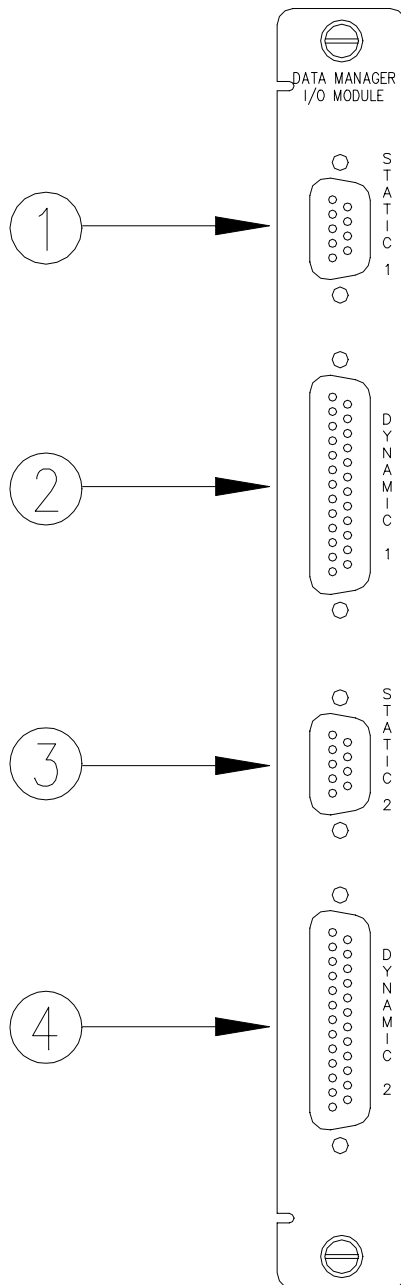

- 1) Used to transfer the static information from Port 1 of this 3500 rack to the static connector on the Communication Processor.
- 2) Used to transfer the dynamic information from Port 1 of this 3500 rack to the dynamic connector on the Communication Processor.
- 3) Used to transfer the information from Port 2 of this 3500 rack to the static connector on the Communication Processor.
- 4) Used to transfer the dynamic information from Port 2 of this 3500 rack to the dynamic connector on the Communication Processor.

Note: The 3500 Monitoring System supports the DDIX and TDIX Communication Processors.

Note: The Data Manager I/O will cease to operate if the Rack Interface Module is removed.

4.2.1 Cable Pin Outs

Cable Number 129386-01
3500 Static to TDIX Cable

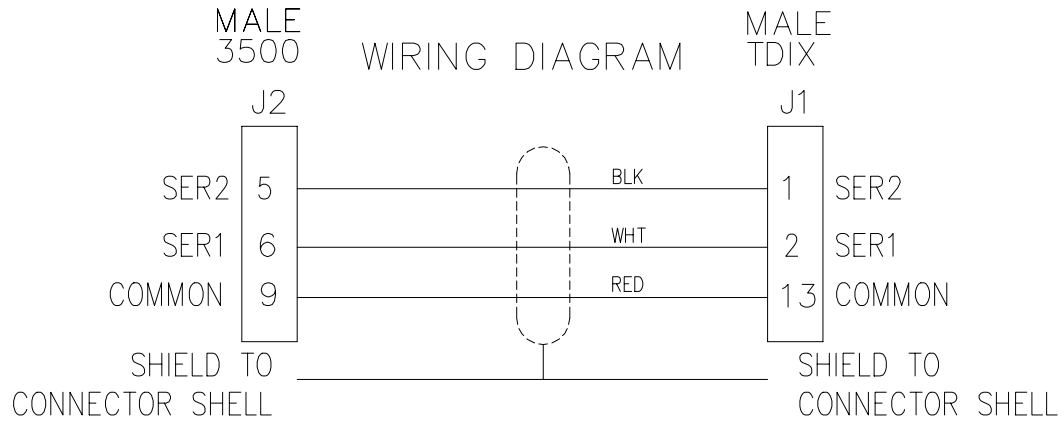

Cable Number 129387-01
3500 Static to DDIX Cable

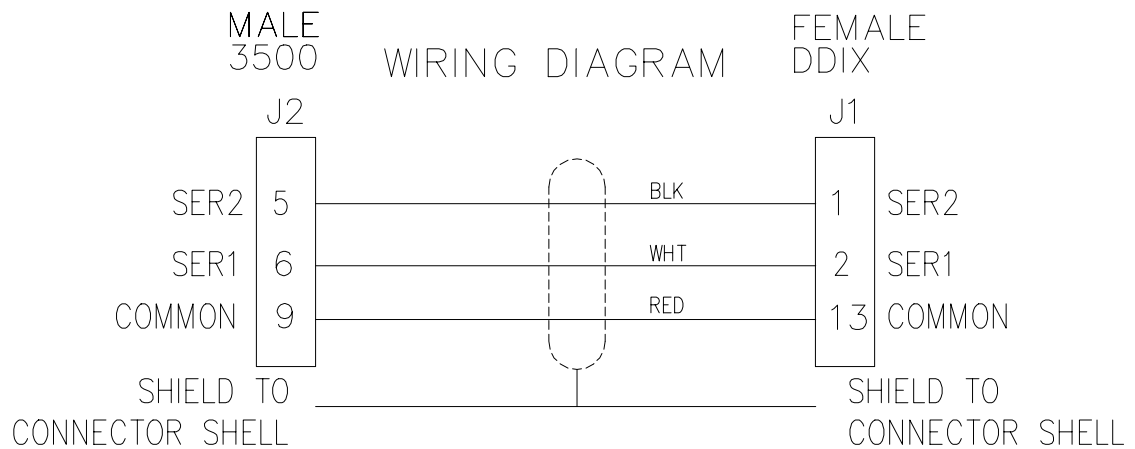

Cable Number 02290160
Dynamic Data Cable DDIX/TDIX

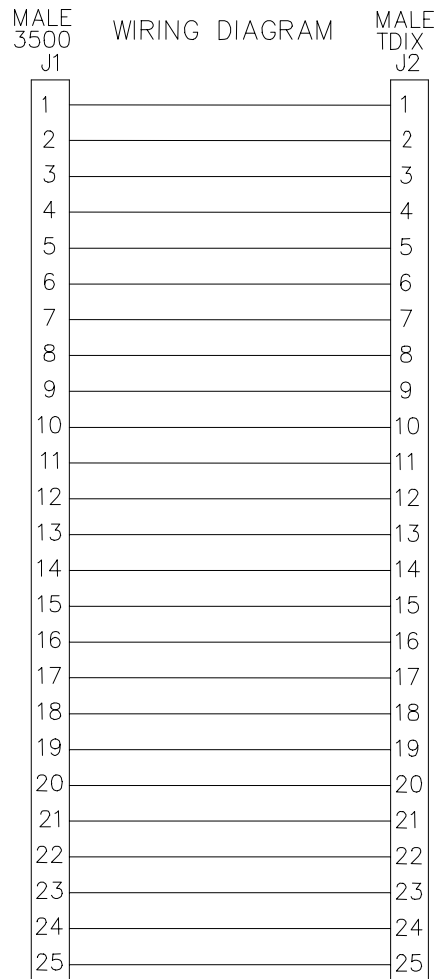

Note: The signals passed through cable 02290160 depend on which dynamic port the cable is connected to on the Data Manager I/O and which 3500 Dynamic options are selected. The following table describes what signals are passed through Dynamic ports 1 and 2 depending on the options chosen.

Signal Pin Out Tables for Dynamic Connectors 1 and 2

Dynamic 1 Connector Pin Number	3500 System Dynamic Signal Option			
	1	2	3	4
1	NONE	NONE	NONE	NONE
7	2,1	2,1	2,1	2,1
14	2,2	2,2	2,2	2,2
18	2,3	2,3	2,3	2,3
16	2,4	2,4	2,4	2,4
11	3,1	4,1	5,1	6,1
21	3,2	4,2	5,2	6,2
25	3,3	4,3	5,3	6,3
23	3,4	4,4	5,4	6,4
2	4,1	6,1	8,1	10,1
9	4,2	6,2	8,2	10,2
4	4,3	6,3	8,3	10,3
6	4,4	6,4	8,4	10,4
20	5,1	8,1	11,1	NONE
3	5,2	8,2	11,2	NONE
19	5,3	8,3	11,3	NONE
5	5,4	8,4	11,4	NONE
24	6,1	10,1	NONE	NONE
10	6,2	10,2	NONE	NONE
13	6,3	10,3	NONE	NONE
12	6,4	10,4	NONE	NONE
15	7,1	12,1	NONE	NONE
22	7,2	12,2	NONE	NONE
17	7,3	12,3	NONE	NONE
8	7,4	12,4	NONE	NONE
Legend: [2,1] refers to Rack Slot 2, Monitor Channel 1				

Dynamic 2 Connector Pin Number	3500 System Dynamic Signal Option			
	1	2	3	4
1	NONE	NONE	NONE	NONE
7	8,1	NONE	NONE	NONE
14	8,2	NONE	NONE	NONE
18	8,3	NONE	NONE	NONE
16	8,4	NONE	NONE	NONE
11	9,1	NONE	NONE	NONE
21	9,2	NONE	NONE	NONE
25	9,3	NONE	NONE	NONE
23	9,4	NONE	NONE	NONE
2	10,1	NONE	NONE	NONE
9	10,2	NONE	NONE	NONE
4	10,3	NONE	NONE	NONE
6	10,4	NONE	NONE	NONE
20	11,1	NONE	NONE	NONE
3	11,2	NONE	NONE	NONE
19	11,3	NONE	NONE	NONE
5	11,4	NONE	NONE	NONE
24	12,1	NONE	NONE	NONE
10	12,2	NONE	NONE	NONE
13	12,3	NONE	NONE	NONE
12	12,4	NONE	NONE	NONE
15	13,1	NONE	NONE	NONE
22	13,2	NONE	NONE	NONE
17	13,3	NONE	NONE	NONE
8	13,4	NONE	NONE	NONE
Legend: [2,1] refers to Rack Slot 2, Monitor Channel 1				

5 Maintenance

This section shows how to verify that the Rack Interface Module and the I/O modules are operating correctly.

When performed properly, this module may be installed into or removed from the rack while power is applied to the rack. Refer to the Rack Installation and Maintenance Manual (part number 129766-01) for the proper procedure.

5.1 RIM Host Port Test Utility

Use the RIM Host Port Test Utility to verify that the HOST ports on the Rack Interface Module and the Rack Interface I/O Module are operating properly. Before running the RIM Host Port Test Utility, connect Cable 130118-XXXX-XX (Host to 3500 Rack RS-232 Interface Cable) between the Configuration Port connector on the front of the Rack Interface Module or to the HOST connector on the Rack Interface I/O Module and the computer that has the utility installed.

Refer to the 3500 Monitoring System Rack Configuration and Utilities Guide and the Rack Configuration Software for the details of this utility.

5.2 Performing Firmware Upgrades

Occasionally it may be necessary to replace the original firmware that is shipped with the 3500/20 Rack Interface Module (RIM). The following instructions describe how to remove the existing firmware and replace it with upgrade firmware. The RIM will need to be reconfigured using the 3500 Rack Configuration software after having its firmware upgraded.

The following items will be required to perform a firmware upgrade to the RIM:

- Large Flathead Screwdriver.
- Grounding Wrist Strap.*
- Small Flathead Screwdriver
- Upgrade Firmware IC.*

*Refer to Section 7 (Ordering Information) for part numbers. Users may use their own grounding wrist strap.

5.2.1 Installation Procedure

The following steps will need to be followed to complete the RIM firmware upgrade:

- Ensure that the Rack Interface Module's configuration is saved using the 3500 Rack Configuration software.

- Refer to Section 1.2 (Handling and Storing Considerations) before handling the RIM or the upgrade firmware IC.

- Remove the RIM from the 3500 rack.
- Remove the Top Shield from the RIM.
- Remove the original firmware IC from the RIM PWA.
- Install the upgrade firmware IC into the socket on the RIM PWA.
- Replace the RIM Top Shield.
- Replace the RIM into the 3500 system.
- Reconfigure the RIM using the 3500 Rack Configuration software.

Detailed instructions for some of the steps listed above are provided on the following pages. Please review completely before proceeding.

Top Shield Removal

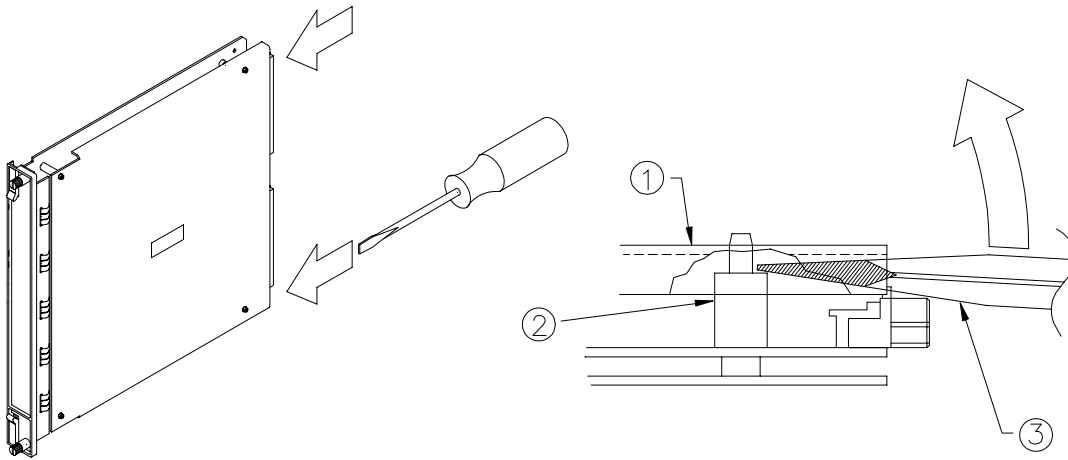

- 1) Top Shield.
- 2) Standoff.
- 3) Screwdriver.

Step 1. Place the large flathead screwdriver under the top shield and on the ridge of the rear standoffs and lift upward on the screwdriver to pop the cover loose from the rear standoffs.

Step 2. Move the top shield up and down to work it loose from the two front standoffs.

Original Firmware IC Removal

Step 1. Insert the small flathead screwdriver under the lip of either end of the IC. The diagram shows the approximate location of the chip to be removed, but not necessarily its orientation.

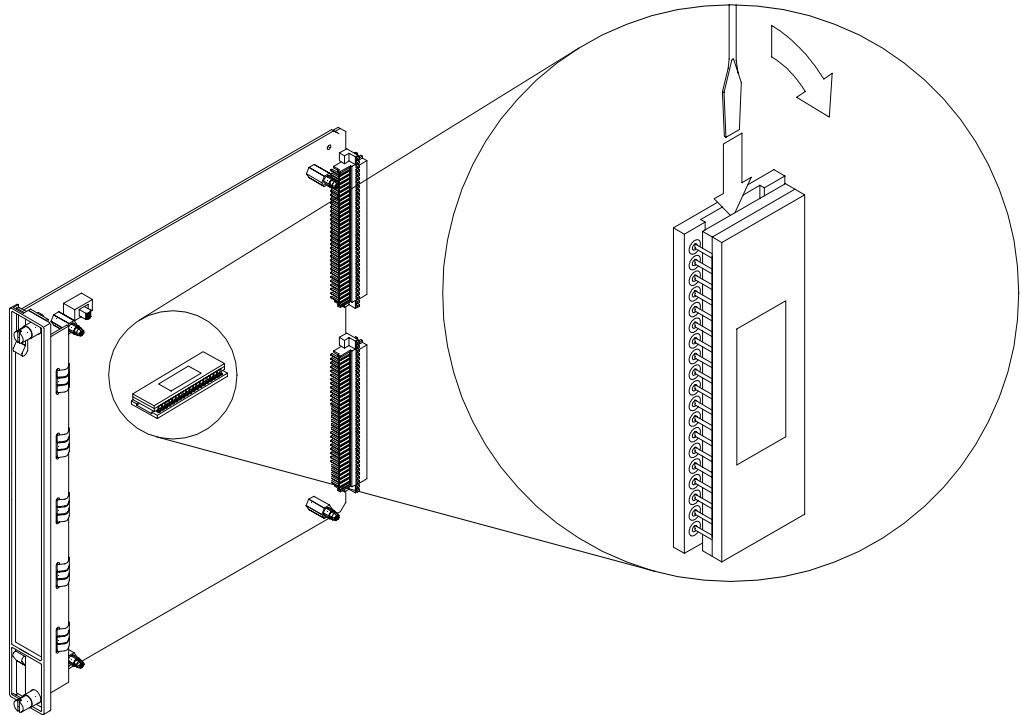

Step 2. Slightly lift the one end of the chip by gently prying with the screwdriver. Move to the other end of the chip and repeat. Continue this process until the chip comes loose from the socket.

Upgrade Firmware IC Installation

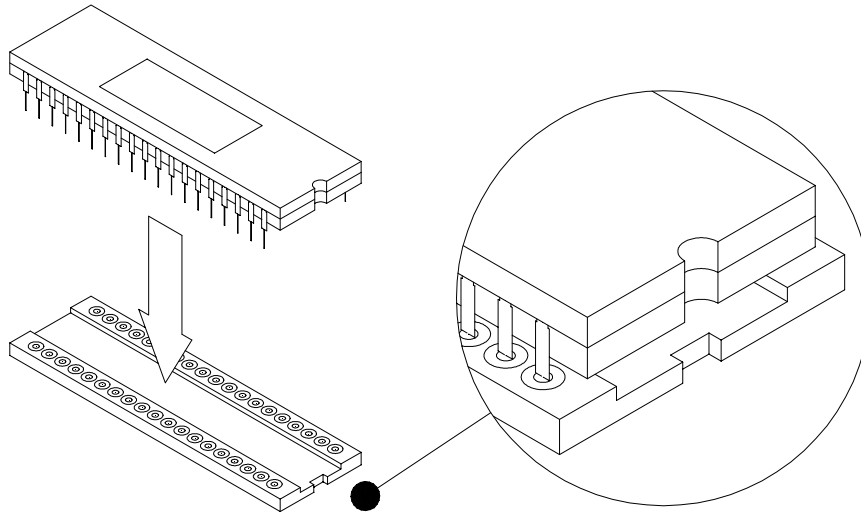

Install the upgrade firmware IC into the PWA. Be sure that the notched end of the IC is matched to the notched end of the socket. Ensure that the IC is firmly seated in the socket.

Top Shield Replacement

Replace the top shield. Be sure that the notch on the top shield is positioned at the top left corner of the module as shown in the diagram under “Top Shield Removal”. Align the holes in the top shield with the standoffs and press down around each standoff until they snap in place.

5.3 Real-Time Clock Replacement

	CAUTION
Dispose of the Real-Time Clock component properly. Do <u>not</u> incinerate!	

The Real-Time Clock component on the Rack Interface Module uses an internal Lithium battery that needs to be replaced every 3 to 10 years. The replacement interval depends on environmental conditions such as operating temperature. A

discharged Lithium battery may cause loss of operating information if the power to the rack is lost. The Real-Time Clock component is socketed for easy replacement. Refer to the System Event List Messages in Section 6 for the message that will be displayed when the Real-Time Clock must be replaced. Contact your nearest Bently Nevada Corporation office for replacement. To replace the Real-Time Clock, follow the instructions in section 5.2 (Performing Firmware Upgrades) with the following exceptions:

The approximate location of the clock component on the Pwa is shown below:

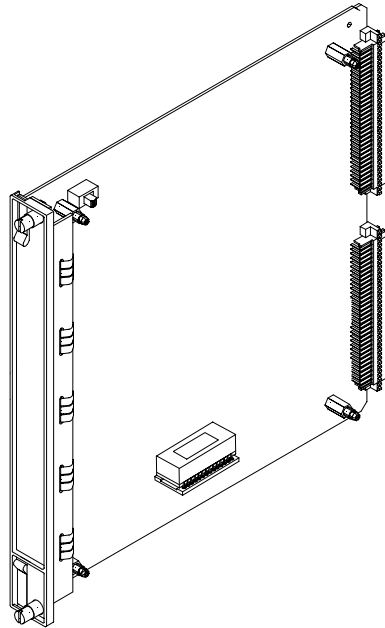

The component and socket line up as shown below:

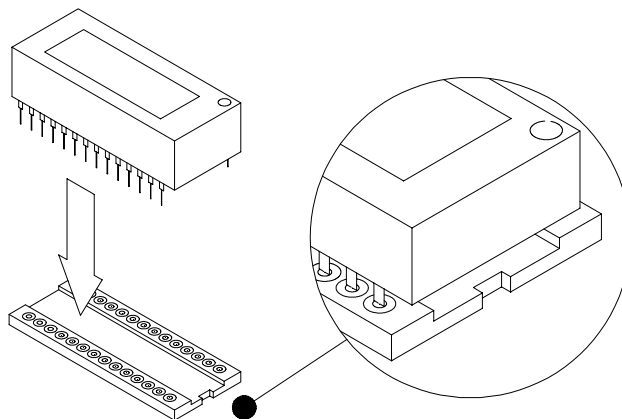

6 Troubleshooting

This section describes how to troubleshoot a problem with the Rack Interface Module or the I/O modules by using the information provided by the verification screen, the LEDs, the System Event List, and the Alarm Event List. You can display the verification screen and the two event lists by using the Rack Configuration Software.

6.1 Verification

To perform the Rack Interface Module's verification:

1. Connect a computer running the Rack Configuration Software to the 3500 rack (if needed).
2. Select **Utilities** from the main screen of the Rack Configuration Software.
3. Select **Verification** from the Utilities menu.
4. Select the Rack Interface Module and select the channel you want to verify.
5. Press the **Verify** button.
6. Select the Front Port or the Rear Port to get the status.
7. The Module OK State will show the Rack Interface Module's status and the Channel OK State will show the channel's status.

6.2 LED Fault Conditions

The following table shows how to use the LEDs to diagnose and correct problems.

OK Led	TX/RX	Condition	Solution
1 Hz	1 Hz	Rack Interface Module is not configured or in Configuration Mode.	Reconfigure the Rack Interface Module.
5 Hz		Rack Interface Module has detected an internal fault and is not OK.	Check the System Event List.
ON	Flashing	Rack Interface Module is operating correctly.	No action is required.
	Not flashing	Rack Interface Module not operating correctly.	Check the System Event List.
<div style="display: flex; align-items: center;"> <div style="width: 20px; height: 20px; background-color: #cccccc; margin-right: 5px;"></div> = behavior of the LED is not related to the condition. </div>			

TM LED	Condition	Solution
ON	Rack is in Trip Multiply (due to hardware or software).	No action is required.
OFF	Rack is not in Trip Multiply.	No action is required.

Config OK LED	Condition	Solution
ON	Configuration information for every module in the rack is valid.	No action is required.
5 Hz	One of the selected security options has had its condition met.	Check the System Event List. Press the Rack Reset switch to clear.
OFF	At least one module has a configuration fault. A non-configured active Power Supply is present in the rack.	Check System Event List for which module(s) need to be reconfigured. OR Reconfigure module(s) that are flashing OK and TX/RX LEDs at 1 Hz. Remove Power Supply or change RIM configuration to include additional Power Supply.

6.3 System Event List Messages

This section describes the System Event List Messages that are entered by the Rack Interface Module.

Example of a System Event List Message

Sequence Number	Event Information	Event Number	Class	Event Date DDMMYY	Event Time	Event Specific	Slot
0000000123	Device Not Communicating	32	1	02/01/90	12:24:31:99		5L

Sequence Number: The number of the event in the System Event List (for example 123).

Event Information: The name of the event (for example Device Not Communicating).

Event Number: Identifies a specific event.

Class: Used to display the severity of the event. The following classes are available:

Class Value	Classification
0	Severe/Fatal Event
1	Potential Problem Event
2	Typical Logged Event
3	Reserved

Event Date: The date the event occurred.

Event Time: The time the event occurred.

Event Specific: Provides additional information for the events that use this field.

Slot: Identifies the module that the event is associated with. If a half-height module is installed in the upper slot or a full-height module is installed, the field will be 0 to 15. If a half-height module is installed in the lower slot, then the field will be 0L to 15L. For example, the module is installed in the lower position of slot 5 (5L).

The following System Event List Messages may be placed in the list by the Rack Interface Module and are listed in numerical order. If an event marked with a star (*) occurs...

- the host link on the back of the Rack Interface I/O Module supplying the message will not communicate with the host computer
- the other Rack Interface Modules in the daisy chain will still be able to communicate with the host computer
- both ports of the Data Manager I/O Module will stop communicating

If you are unable to solve any problems, contact your nearest Bently Nevada Corporation office.

Flash Memory Failure

Event Number: 11

Event Classification: Potential Problem

Action: Replace the Rack Interface Module as soon as possible.

Real Time Clock Failure

Event Number: 12

Event Classification: Severe/Fatal Event

Action: Replace the Real Time Clock in the Rack Interface Module immediately.

Internal Network Failure

Event Number: 30

Event Classification: Severe/Fatal Event

Action: Replace the Rack Interface Module immediately.

Resync Internal Network (Resynchronize Internal Network)

Event Number: 31

Event Classification: Potential Problem

Action: Check to see if one of the following components is faulty:

- the Rack Interface Module
- the rack backplane

Device Not Communicating

Event Number: 32

Event Classification: Potential Problem

Action: Check to see if one of the following components is faulty:

- the module installed in the slot
- the rack backplane

Device Is Communicating

Event Number: 33

Event Classification: Potential Problem

Action: Check to see if one of the following components is faulty:

- the module installed in the slot
- the rack backplane

Config Token Acquired (Configuration Token Acquired)

Event Number: 50

Event Classification: Typical logged event

Event Specific: Front,
Back,
DM1 (Data Manager port 1),
DM2 (Data Manager port 2),
ComGate (Communication Gateway)

The specified port can download configuration, change setpoints, set software switches, enable/disable Rack Alarm Inhibit, enable/disable Trip Multiply, or perform Rack Reset.

Action: No action required.

Config Token Released (Configuration Token Released)

Event Number: 51

Event Classification: Typical logged event

Event Specific: Front,
Back,
DM1 (Data Manager port 1),
DM2 (Data Manager port 2),
ComGate (Communication Gateway)

The specified port can no longer download configuration, change setpoints, set software switches, enable/disable Rack Alarm Inhibit, enable/disable Trip Multiply, or perform Rack Reset.

Action: No action required.

Config Token Expired (Configuration Token Expired)

Event Number: 52

Event Classification: Potential Problem

Action: Check to see if one of the following components is faulty:

- the connection between the Rack Interface Module and the computer running the Rack Configuration Software
- the Rack Interface Module
- the computer running the Rack Configuration Software

Config Token Override (Configuration Token Override)

Event Number: 53

Event Classification: Typical Logged Event

Action: No action required.

Fail Relay Coil Sense

Event Number: 55

Event Classification: Potential Problem

Action: Check to see if the Rack Interface I/O Module is installed. If installed, check to see if one of the following components is faulty:

- the Rack Interface Module
- the Rack Interface I/O Module

Pass Relay Coil Sense

Event Number: 56

Event Classification: Potential Problem

Action: Check to see if the Rack Interface I/O Module is installed. If installed, check to see if one of the following components is faulty:

- the Rack Interface Module
- the Rack Interface I/O Module

I/O Module Mismatch

Event Number: 60

Event Classification: Potential Problem

Action: Verify that the Rack Interface I/O Module installed matches the Rack Interface I/O Module selected in the Rack Configuration Software. If the correct Rack Interface I/O Module is installed, there could be a fault with the installed Rack Interface I/O Module.

Rack Type Mismatch

Event Number: 61

Event Classification: Potential Problem

Action: Verify that the rack selection jumper, installed on the rack backplane, matches the rack type selected in the software. If the jumper is installed in the correct position, there could be a fault with the rack backplane.

HW Rack Alm Inh Active (Hardware Rack Alarm Inhibit Active)

Event Number: 70

Event Classification: Typical Logged Event

Action: No action required.

HW Rack Alm Inh Inactive (Hardware Rack Alarm Inhibit Inactive)

Event Number: 71

Event Classification: Typical Logged Event

Action: No action required.

HW override of SW Inh (Hardware override of Software Inhibit)

Event Number: 72

Event Classification: Typical Logged Event

Action: No action required.

HW Trip Multiply Active (Hardware Trip Multiply Active)

Event Number: 73

Event Classification: Typical Logged Event

Action: No action required.

HW Trip Mult Inactive (Hardware Trip Multiply Inactive)

Event Number: 74

Event Classification: Typical Logged Event

Action: No action required.

HW override of SW TM (Hardware override of Software Trip Multiply)

Event Number: 75

Event Classification: Typical Logged Event

Action: No action required.

HW Rack Reset Active (Hardware Rack Reset Active)

Event Number: 76

Event Classification: Typical Logged Event

Action: No action required.

HW Rack Reset Inactive (Hardware Rack Reset Inactive)

Event Number: 77

Event Classification: Typical Logged Event

Action: No action required.

SW Rack Alm Inh Active (Software Rack Alarm Inhibit Active)

Event Number: 78

Event Classification: Typical Logged Event

Action: No action required.

SW Rack Alm Inh Inactive (Software Rack Alarm Inhibit Inactive)

Event Number: 79

Event Classification: Typical Logged Event

Action: No action required.

SW Trip Multiply Active (Software Trip Multiply Active)

Event Number: 80

Event Classification: Typical Logged Event

Action: No action required.

SW Trip Mult Inactive (Software Trip Multiply Inactive)

Event Number: 81

Event Classification: Typical Logged Event

Action: No action required.

SW Rack Reset (Software Rack Reset)

Event Number: 82

Event Classification: Typical Logged Event

Action: No action required.

Rack Address changed

Event Number: 90

Event Classification: Typical Logged Event

Action: No action required.

Key Switch in Run Mode

Event Number: 91

Event Classification: Typical Logged Event

Action: No action required.

Key Switch in Prgm Mode (Key Switch in Program Mode)

Event Number: 92

Event Classification: Typical Logged Event

Action: No action required.

Fail Main Board +5V-A (Fail Main Board +5V - upper Power Supply)

Event Number: 100

Event Classification: Potential Problem

Action: Verify that noise from the power source is not causing the problem. If the problem is not caused by noise, check to see if one of the following components is faulty:

- the Rack Interface Module
- the Power Supply installed in the upper slot

Pass Main Board +5V-A (Pass Main Board +5V - upper Power Supply)

Event Number: 101

Event Classification: Potential Problem

Action: Verify that noise from the power source is not causing the problem. If the problem is not caused by noise, check to see if one of the following components is faulty:

- the Rack Interface Module
- the Power Supply installed in the upper slot

Fail Main Board +5V-B (Fail Main Board +5V - lower Power Supply)

Event Number: 102

Event Classification: Potential Problem

Action: Verify that noise from the power source is not causing the problem. If the problem is not caused by noise, check to see if one of the following components is faulty:

- the Rack Interface Module
- the Power Supply installed in the lower slot

Pass Main Board +5V-B (Pass Main Board +5V - lower Power Supply)

Pass Main Board +5V-B

Event Number: 103

Event Classification: Potential Problem

Action: Verify that noise from the power source is not causing the problem. If the problem is not caused by noise, check to see if one of the following components is faulty:

- the Rack Interface Module
- the Power Supply installed in the lower slot

*** Fail Main Board +5V-AB** (Fail Main Board +5V - upper and lower Power Supplies)

Event Number: 104

Event Classification: Severe / Fatal Event

Action: Verify that noise from the power source is not causing the problem. If the problem is not caused by noise, check to see if one of the following components is faulty:

- the Rack Interface Module
- the Power Supply installed in the lower slot
- the Power Supply installed in the upper slot

Pass Main Board +5V-AB (Pass Main Board +5V - upper and lower Power Supplies)

Event Number: 105

Event Classification: Severe / Fatal Event

Action: Verify that noise from the power source is not causing the problem. If the problem is not caused by noise, check to see if one of the following components is faulty:

- the Rack Interface Module
- the Power Supply installed in the lower slot
- the Power Supply installed in the upper slot

Fail Main Board +15V-A (Fail Main Board +15V - upper Power Supply)

Event Number: 106

Event Classification: Potential Problem

Action: Verify that noise from the power source is not causing the problem. If the problem is not caused by noise, check to see if one of the following components is faulty:

- the Rack Interface Module
- the Power Supply installed in the upper slot

Pass Main Board +15V-A (Pass Main Board +15V - upper Power Supply)

Event Number: 107

Event Classification: Potential Problem

Action: Verify that noise from the power source is not causing the problem. If the problem is not caused by noise, check to see if one of the following components is faulty:

- the Rack Interface Module
- the Power Supply installed in the upper slot

Fail Main Board +15V-B (Fail Main Board +15V - lower Power Supply)

Event Number: 108

Event Classification: Potential Problem

Action: Verify that noise from the power source is not causing the problem. If the problem is not caused by noise, check to see if one of the following components is faulty:

- the Rack Interface Module
- the Power Supply installed in the lower slot

Pass Main Board +15V-B (Pass Main Board +15V - lower Power Supply)

Event Number: 109

Event Classification: Potential Problem

Action: Verify that noise from the power source is not causing the problem. If the problem is not caused by noise, check to see if one of the following components is faulty:

- the Rack Interface Module
- the Power Supply installed in the lower slot

*** Fail Main Board +15V-AB** (Fail Main Board +15V - upper and lower Power Supplies)

Event Number: 110

Event Classification: Severe / Fatal Event

Action: Verify that noise from the power source is not causing the problem. If the problem is not caused by noise, check to see if one of the following components is faulty:

- the Rack Interface Module
- the Power Supply installed in the lower slot
- the Power Supply installed in the upper slot

Pass Main Board +15V-AB (Pass Main Board +15V - upper and lower Power Supplies)

Event Number: 111

Event Classification: Severe / Fatal Event

Action: Verify that noise from the power source is not causing the problem. If the problem is not caused by noise, check to see if one of the following components is faulty:

- the Rack Interface Module
- the Power Supply installed in the lower slot
- the Power Supply installed in the upper slot

Fail Main Board -24V-A (Fail Main Board -24V - upper Power Supply)

Event Number: 112

Event Classification: Potential Problem

Action: Verify that noise from the power source is not causing the problem. If the problem is not caused by noise, check to see if one of the following components is faulty:

- the Rack Interface Module
- the Power Supply installed in the upper slot

Pass Main Board -24V-A (Pass Main Board -24V - upper Power Supply)

Event Number: 113

Event Classification: Potential Problem

Action: Verify that noise from the power source is not causing the problem. If the problem is not caused by noise, check to see if one of the following components is faulty:

- the Rack Interface Module
- the Power Supply installed in the upper slot

Fail Main Board -24V-B (Fail Main Board -24V -upper and lower Power Supply)

Event Number: 114

Event Classification: Potential Problem

Action: Verify that noise from the power source is not causing the problem. If the problem is not caused by noise, check to see if one of the following components is faulty:

- the Rack Interface Module
- the Power Supply installed in the lower slot

Pass Main Board -24V-B (Pass Main Board -24V - lower Power Supply)

Event Number: 115

Event Classification: Potential Problem

Action: Verify that noise from the power source is not causing the problem. If the problem is not caused by noise, check to see if one of the following components is faulty:

- the Rack Interface Module
- the Power Supply installed in the lower slot

* **Fail Main Board -24V-AB** (Fail Main Board -24V - upper and lower Power Supplies)

Event Number: 116

Event Classification: Severe / Fatal Event

Action: Verify that noise from the power source is not causing the problem. If the problem is not caused by noise, check to see if one of the following components is faulty:

- the Rack Interface Module
- the Power Supply installed in the lower slot
- the Power Supply installed in the upper slot

Pass Main Board -24V-AB (Pass Main Board -24V - upper and lower Power Supplies)

Event Number: 117

Event Classification: Severe / Fatal Event

Action: Verify that noise from the power source is not causing the problem. If the problem is not caused by noise, check to see if one of the following components is faulty:

- the Rack Interface Module
- the Power Supply installed in the lower slot
- the Power Supply installed in the upper slot

Device Configured

Event Number: 300

Event Classification: Typical Logged Event

Action: No action required.

Configuration Failure

Event Number: 301

Event Classification: Severe/Fatal Event

Action: Replace the Rack Interface Module immediately.

Configuration Failure

Event Number: 301

Event Classification: Potential Problem

Action: Download a new configuration to the Rack Interface Module. If the problem still exists, replace the Rack Interface Module as soon as possible.

Module Entered Cfg Mode (Module Entered Configuration Mode)

Event Number: 302

Event Classification: Typical Logged Event

Action: No action required.

Software Switches Reset

Event Number: 305

Event Classification: Potential Problem

Action: Download the software switches to the Rack Interface Module. If the software switches are not correct, replace the Rack Interface Module as soon as possible.

Init Real Time Clock (Initialize Real Time Clock)

Event Number: 306

Event Classification: Potential Problem

Action: Replace the Real-Time Clock component in the Rack Interface Module as soon as possible.

Monitor TMR PPL Failed (Monitor TMR Proportional value Failed)

Event Number: 310

Event Classification: Potential Problem

Action: Replace the monitor installed in the slot as soon as possible.

Monitor TMR PPL Passed (Monitor TMR Proportional value Passed)

Event Number: 311

Event Classification: Potential Problem

Action: Replace the monitor installed in the slot as soon as possible.

Module Reboot

Event Number: 320

Event Classification: Typical Logged Event

Action: No action required.

Module Removed from Rack

Event Number: 325

Event Classification: Typical Logged Event

Action: No action required.

Module Inserted in Rack

Event Number: 326

Event Classification: Typical Logged Event

Action: No action required.

Supply OK/Installed

Event Number: 330

Event Classification: Potential Problem

Action: Determine if a power supply has been installed. Verify that there is not a problem with the power source. If there are no problems with the power source, replace the power supply as soon as possible.

Supply Faulted/Removed

Event Number: 331

Event Classification: Potential Problem

Action: Determine if a power supply has been removed. Verify that there is not a problem with the power source. If there are no problems with the power source, replace the power supply as soon as possible.

Rack/RIM Powered Down (Rack or Rack Interface Module Powered Down)

Event Number: 340

Event Classification: Typical Logged Event

Action: No action required.

Rack/RIM Powered Up (Rack or Rack Interface Module Powered Up)

Event Number: 341

Event Classification: Typical Logged Event

Action: No action required.

Modem Reinitialized

Event Number: 350

Event Classification: Typical Logged Event

Action: No action required.

Device Events Lost

Event Number: 355

Event Classification: Typical Logged Event

Action: No action required.

Module Alarms Lost

Event Number: 356

Event Classification: Typical Logged Event

Action: No action required.

Rack Time Changed

Event Number: 360

Event Classification: Typical Logged Event

Action: No action required.

Module Entered Calibr. (Module Entered Calibration Mode)

Event Number: 365

Event Classification: Typical Logged Event

Action: No action required.

Module Exited Calibr. (Module Exited Calibration Mode)

Event Number: 366

Event Classification: Typical Logged Event

Action: No action required.

Config Password Changed (Configuration Password Changed)

Event Number: 400

Event Classification: Typical Logged Event

Action: No action required.

Connect Password Changed

Event Number: 401

Event Classification: Typical Logged Event

Action: No action required.

6.4 Alarm Event List Messages

The following Alarm Event List Messages are returned by the different module types installed in the 3500 rack.

<u>Communication Gateway Module</u>	<u>When the message will occur</u>
Entered not OK	module went not OK
Left not OK	module returned to the OK state
<u>Keyphasor Module</u>	<u>When the message will occur</u>
Entered not OK	module went not OK
Left not OK	module returned to the OK state

<u>Monitor Module</u>	<u>When the message will occur</u>
Entered Alert / Alarm 1	A proportional value in the channel has entered Alert / Alarm 1 and changed the channel Alert / Alarm 1 status
Left Alert / Alarm 1	A proportional value in the channel has left Alert / Alarm 1 and changed the channel Alert / Alarm 1 status
Entered Danger / Alarm 2	A proportional value in the channel has entered Danger / Alarm 2 and changed the channel Danger / Alarm 2 status
Left Danger / Alarm 2	A proportional value in the channel has left Danger / Alarm 2 and changed the channel Danger / Alarm 2 status
Entered not OK	module went not OK
Left not OK	module returned to the OK state
<u>Rack Interface Module</u>	<u>When the message will occur</u>
Entered not OK	module went not OK
Left not OK	module returned to the OK state
<u>Relay Module</u>	<u>When the message will occur</u>
Entered not OK	module went not OK
Left not OK	module returned to the OK state
Relay Activated	condition for driving the relay channel met
Relay Deactivated	condition for driving the relay channel is not met anymore

7 Ordering Information

Part number 3500/20 - A B C
 - XX - XX - XX

A Rack Interface Type

- 01 Standard RIM (Use for standard monitoring applications)
- 02 TMR RIM (Use only for application that requires a Triple Modular Redundant Configuration)

B Type of I/O Module

- 01 I/O Module with built-in Modem
- 02 I/O Module with RS-232/RS-422 Interface

C Agency Approval Option

- 00 None
- 01 CSA-NRTL/C

Spares

Standard Rack Interface Module	125744-02
TMR Rack Interface Module	125744-01
RIM I/O Module with Modem Interface	135031-01
RIM I/O Module with RS-232/RS-422 Interface	125768-01
Data Manager I/O Module	125760-01
RIM Module Manual	129768-01
I/O Module Connector Header, Euro Style, 6 Pin	00580437
I/O Module Connector Header, Euro Style, 3 Pin	00580440
Grounding Wrist Strap (single use only)	04425545
Real -Time Clock IC	00801286
Serial Data Isolator	02200633
*Firmware IC	128755-01

*Firmware ICs are available only for PWA 125744-01 revision P or later, or for PWA 125744-02 revision N or later.

Cables

RS-232 Modem cable from:	02290860
3500 Rack External Modem	
Host Computer to External Modem	
Host Computer to RS-232/422	
Converter Cable RS-232	130119-01
TDIX - Static Data Cable	129386-01
DDIX - Static Data Cable	129387-01
DDIX/TDIX - Dynamic Data Cable	02290160
RS-232 to RS-422 Converter 110 VAC	02230411
RS-232 to RS-422 Converter 220 VAC	02230412

Host Computer to 3500 Rack Cable RS-232

A B

Part number 130118 - XXXX - XX

A	Cable Length
0010	10 feet (3 meters)
0025	25 feet (7.5 meters)
0050	50 feet (15 meters)
100	100 feet (30.5 meters)

B	Assembly Instructions
01	Not Assembled
02	Assembled

Host Computer to 3500 Rack Cable RS-422 PVC

A B

Part number 132632 - XXXX - XX

A	Cable Length
0010	10 feet (3 meters)
0025	25 feet (7.5 meters)
0050	50 feet (15 meters)
0100	100 feet (30.5 meters)
0250	250 feet (76 meters)
500	500 feet (152 meters)

B	Assembly Instructions
01	Not Assembled
02	Assembled

Host Computer to 3500 Rack Cable RS-422 Teflon

A B

Part number 132633 - XXXX - XX

A	Cable Length
0010	10 feet (3 meters)
0025	25 feet (7.5 meters)
0050	50 feet (15 meters)
0100	100 feet (30.5 meters)
0250	250 feet (76 meters)
500	500 feet (152 meters)

B	Assembly Instructions
01	Not Assembled
02	Assembled

RS-232/422 Converter to 3500 Rack Cable RS-422 PVC Insulated

A B

Part number 130120 - XXXX - XX

A	Cable Length
0010	10 feet (3 meters)
0025	25 feet (7.5 meters)
0050	50 feet (15 meters)
0100	100 feet (30.5 meters)
0250	250 feet (76 meters)
0500	500 feet (152 meters)

B	Assembly Instructions
01	Not Assembled
02	Assembled

RS-232/422 Converter to 3500 Rack Cable RS-422 Teflon Insulated

A B

Part number 131106 - XXXX - XX

A	Cable Length
0010	10 feet (3 meters)
0025	25 feet (7.5 meters)
0050	50 feet (15 meters)
0100	100 feet (30.5 meters)
0250	250 feet (76 meters)
0500	500 feet (152 meters)

B	Assembly Instructions
01	Not Assembled
02	Assembled

3500 Rack to 3500 Rack Cable RS-422 PVC Insulated

A B

Part number 130122 - XXXX - XX

A	Cable Length
0010	10 feet (3 meters)
0025	25 feet (7.5 meters)
0050	50 feet (15 meters)
0100	100 feet (30.5 meters)
0250	250 feet (76 meters)
0500	500 feet (152 meters)

B	Assembly Instructions
01	Not Assembled
02	Assembled

3500 Rack to 3500 Rack Cable RS-422 Teflon Insulated

A B

Part number 131107 - XXXX - XX

A	Cable Length
0010	10 feet (3 meters)
0025	25 feet (7.5 meters)
0050	50 feet (15 meters)
0100	100 feet (30.5 meters)
0250	250 feet (76 meters)
0500	500 feet (152 meters)

B	Assembly Instructions
01	Not Assembled
02	Assembled

Extension Cable RS-422 (Used with Cables 130120, 131106, 130122 and 131107 for lengths greater than 500 feet [152 meters])

A B

Part number 130121 - XX - XX

A	Assembly Instructions
01	Not Assembled
02	Assembled

B	Insulation
01	PVC Insulated
02	Teflon Insulated

8 Specifications

INPUTS

Power Consumption:	4.75 watts maximum
Data:	
Front panel:	38.4 kbaud maximum RS-232 serial communications
I/O modules:	38.4 kbaud maximum RS-232/RS-422 serial communications 14.4 kbaud internal modem communications

OUTPUTS

Front Panel LEDs:	
OK LED:	Indicates when the RIM is operating properly.
TX/RX LED:	Indicates when the RIM is communicating with other modules in the 3500 rack.
TM LED:	Indicates when the 3500 rack is in Trip Multiply.
CONFIG OK LED:	Indicates that the 3500 rack has a valid configuration.

Data Manager I/O Dynamic Data Port:	Provides Multiplexed Buffered Transducer signals through the Data Manager I/O Module. Output Impedance: 600 Ohms Note: The combined parallel impedance of all loads connected to Dynamic Data Port and Buffered Transducer Outputs should be a minimum of 6K Ohms. A smaller load impedance than this could affect the accuracy of the readings.
--	--

Static Data Port:	Makes Static Data available to Communication Processor. Output Impedance: 1K Ohms
-------------------	--

I/O Module OK Relay:	Relay to indicate when the 3500 rack is operating normally or when a fault has been detected within the rack. User can select either an "OPEN" or "CLOSED" contact to annunciate a not OK condition. This relay always operates as "Normally Energized."
----------------------	--

OK relay (resistive load):	Max switched power: DC: 120 W AC: 600 VA Max switched current: 5 A Min switched current: 100 mA @ 5 Vdc Max switched voltage: DC: 30Vdc AC: 120 Vac Contact life: 100,000 @ 5 A, 24 Vdc or 120 Vac Environmental sealing: Epoxy sealed
----------------------------	---

Normally closed contacts: Arc suppressors are provided (250 Vrms).

Maximum Switching Capacity DC Resistive Load

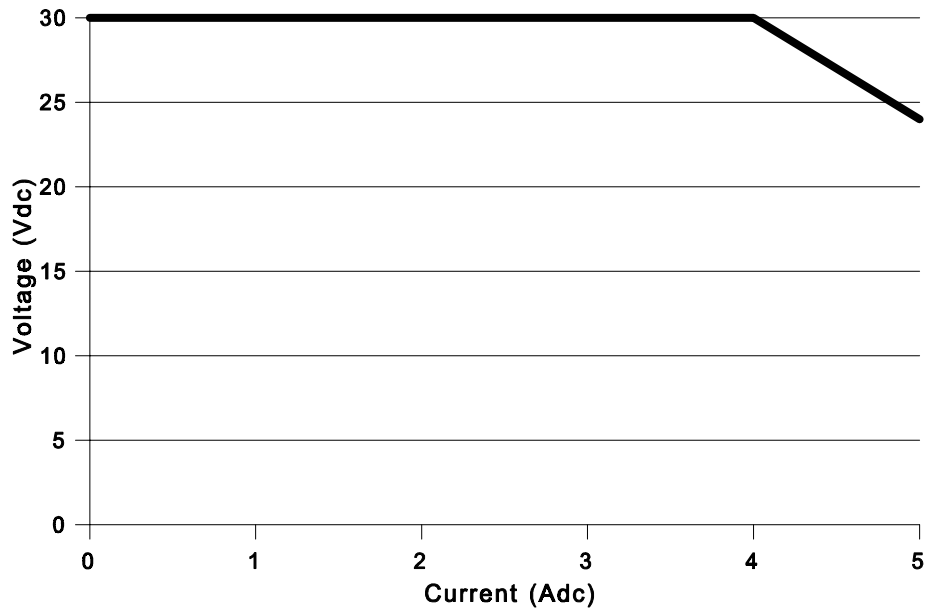

Maximum Switching Capacity AC Resistive Load

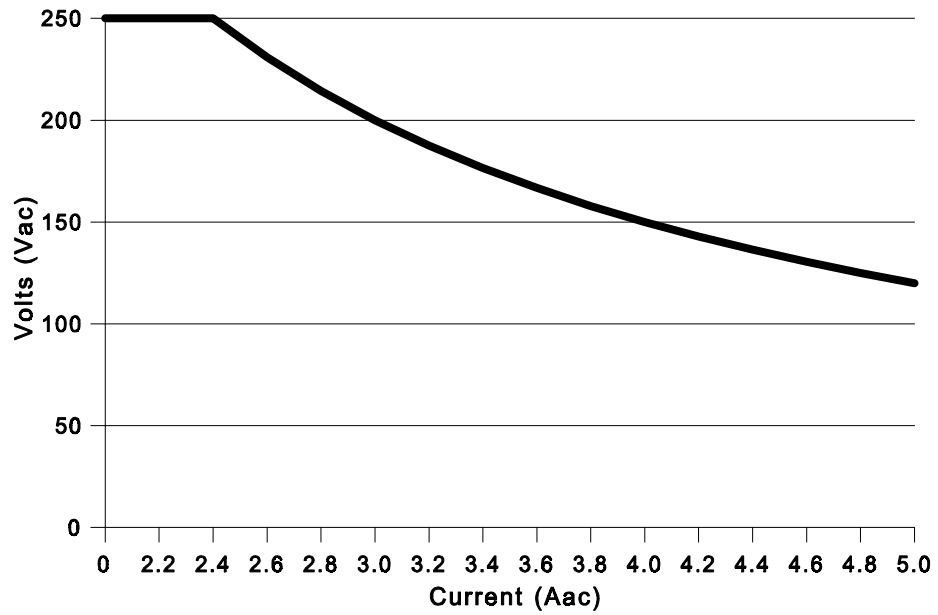

CONTROLS

Front Panel:

- Rack reset button: Clears latched alarms and Timed OK Channel Defeat in the rack. Performs same function as "Rack Reset" contact on I/O module.
- Address switch: Used to set the rack address. 63 possible addresses.
- Configuration Keylock: Used to place 3500 rack in either RUN mode or PROGRAM mode. RUN mode allows for normal operation of the rack and locks out configuration changes. PROGRAM mode allows for normal operation of the rack and also allows for local or remote rack configuration. Key can be removed from rack in either position, allowing switch to remain in either RUN or PROGRAM positions. Locking switch in the RUN position allows you to restrict unauthorized rack configuration. Locking switch in PROGRAM position allows remote configuration of a rack at any time.

I/O Module System Contacts:

- Trip multiply: Used to place 3500 rack in Trip Multiply.
- Alarm inhibit: Used to inhibit all alarms in the 3500 rack.
- Rack reset: Used to clear latched alarms and Timed OK Channel Defeat.
- Maximum Current: <1 mA DC, Dry Contact to Common

RS-232/RS-422 Switch (RS-232/RS-422 I/O module only):

Used to select between RS-232 and RS-422 for communications with the Bently Nevada host software.

COMMUNICATIONS

Front Panel:

- Communications: RS-232 only
- Protocol: Bently Nevada developed
- Baud rate: 38.4 kbaud maximum (auto baud capable)
- Purpose: Permits data collection and 3500 rack configuration
- Cable length: 30 m (100 ft) maximum

RS-232/RS-422 I/O Module:

- Communications: RS-232, RS-422, or external modem
- Protocol: Bently Nevada developed
- Baud rate: 38.4 kbaud maximum (auto baud capable)
- Purpose: Permits data collection and 3500 rack configuration
- Cable length:
- RS-232: 30 m (100 ft) maximum
- RS-422: 1200 m (4000 ft) maximum
- Modem: Consult modem manufacturer, typical 3.0 m (10 ft)

Modem I/O Module:	
Communications:	Hayes AT-compatible
Protocol:	Bently Nevada developed
Baud rate:	Up to 14.4k baud
Purpose:	Permits data collection and 3500 rack configuration
Cable length:	2.1 m (7 ft) maximum modem to phone jack
Rack Connector:	
Communications:	RS-422 only
Protocol:	Bently Nevada developed
Baud rate:	38.4 kbaud maximum
Purpose:	Allows multiple 3500 racks to be daisy chained together for communications with 3500 Host Software
Cable length:	1200 m (4000 ft) maximum
Data Manager I/O Module (2 sets of ports):	
Communications:	Bently Nevada developed
Protocol:	Bently Nevada developed
Baud rate:	9600 baud only
Purpose:	Permits static and dynamic data collection by Bently Nevada Transient Data Interface External or Dynamic Data Interface External Communication Processors
Cable length:	3.0 m (10 ft) maximum

ENVIRONMENTAL LIMITS

Rack Interface Module and RS232/RS422 I/O

Operating Temperature	-30° C to 65° C (-22° F to 150° F)
Storage Temperature	-40° C to 85° C (-40° F to 185° F)

Modem I/O Module

Operating Temperature	0° C to 50° C (32° F to 122° F)
Storage Temperature	-40° C to 85° C (-40° F to 185° F)

Humidity: 95% non-condensing

CE MARK DIRECTIVES:

EMC Directives:

EN50081-2:

Radiated Emissions:	EN 55011, Class A
Conducted Emissions:	EN 55011, Class A

EN50082-2:

Electrostatic Discharge:	EN 61000-4-2, Criteria B
--------------------------	--------------------------

Radiated Susceptibility:	ENV 50140, Criteria A
Conducted Susceptibility:	ENV 50141, Criteria A
Electrical Fast Transient:	EN 61000-4-4, Criteria B
Surge Capability:	EN 61000-4-5, Criteria B
Magnetic Field:	EN 61000-4-8, Criteria A
Power Supply Dip:	EN 61000-4-11, Criteria B
Radio Telephone:	ENV 50204, Criteria B

Low Voltage Directives:

Safety Requirements:	EN 61010-01
----------------------	-------------

APPROVALS

CSA-NRTL/C:	Class I, Division 2, Groups A through D
-------------	---

PHYSICAL

RIM:

Dimensions (Height x Width x Depth):	241.3 mm x 24.4 mm x 241.8 mm (9.50 in x 0.96 in x 9.52 in)
Weight:	0.91 kg (2.0 lbs)

RS-232/RS-422 I/O:

Dimensions (Height x Width x Depth):	241.3 mm x 24.4 mm x 99.1 mm (9.50 in x 0.96 in x 3.90 in)
Weight:	0.45 kg (1.0 lbs)

Modem I/O:

Dimensions (Height x Width x Depth):	241.3 mm x 24.4 mm x 99.1 mm (9.50 in x 0.96 in x 3.90 in)
Weight:	0.45 kg (1.0 lbs)

Data Manager I/O:

Dimensions (Height x Width x Depth):	241.3 mm x 24.4 mm x 99.1 mm (9.50 in x 0.96 in x 3.90 in)
Weight:	0.45 kg (1.0 lbs)

RACK SPACE REQUIREMENTS:

RIM Main Board:	1 full-height front slot
RIM I/O Modules:	1 full-height rear slot
Data Manager I/O Modules:	1 full-height rear slot