



ADVANCED AND EVER ADVANCING **MITSUBISHI ELECTRIC**

 **MITSUBISHI**  
PROGRAMMABLE CONTROLLERS  
MELSEC-F

Art.Nr. 132737  
Version E  
JY992D83901  
2001 10 10

## HARDWARE MANUAL

FX<sub>1S</sub> SERIES PROGRAMMABLE CONTROLLERS

# FX<sub>1S</sub>



## **Foreword**

- This manual contains text, diagrams and explanations which will guide the reader in the correct installation and operation of the FX1S Series Programmable Controllers. It should be read and understood before attempting to install or use the unit.
- Further information can be found in the FX Series Programming Manual II.
- If in doubt at any stage of the installation of an FX1S Series Programmable Controller always consult a professional electrical engineer who is qualified and trained to the local and national standards which apply to the installation site.
- If in doubt about the operation or use of FX1S Series Programmable Controller please consult the nearest Mitsubishi Electric distributor.
- This manual is subject to change without notice.



# FX<sub>1s</sub> Series Programmable Controllers

## Hardware Manual

Manual number : JY992D83901

Manual revision : E

Date : June 2001

## **Guidelines for the Safety of the User and Protection of the FX1s.**

This manual provides information for the use of the FX1s. The manual has been written to be used by trained and competent personnel. The definition of such a person or persons is as follows:

- a) Any engineer who is responsible for the planning, design and construction of automatic equipment using the product associated with this manual, should be of a competent nature, trained and qualified to the local and national standards required to fulfill that role. These engineers should be fully aware of all aspects of safety with regards to automated equipment.
- b) Any commissioning or service engineer must be of a competent nature, trained and qualified to the local and national standards required to fulfill that job. These engineers should also be trained in the use and maintenance of the completed product. This includes being completely familiar with all associated documentation for said product. All maintenance should be carried out in accordance with established safety practices.
- c) All operators of the completed equipment should be trained to use that product in a safe and coordinated manner in compliance to established safety practices. The operators should also be familiar with documentation which is connected with the actual operation of the completed equipment.

**Note :** The term 'completed equipment' refers to a third party constructed device which contains or uses the product associated with this manual.

## Notes on the Symbols Used in this Manual

At various times through out this manual certain symbols will be used to highlight points of information which are intended to ensure the user's personal safety and protect the integrity of equipment. Whenever any of the following symbols are encountered its associated note must be read and understood. Each of the symbols used will now be listed with a brief description of its meaning.

### Hardware Warnings



1) Indicates that the identified danger **WILL** cause physical and property damage.



2) Indicates that the identified danger could **POSSIBLY** cause physical and property damage.



3) Indicates a point of further interest or further explanation.

### Software Warnings



4) Indicates special care must be taken when using this element of software.



5) Indicates a special point which the user of the associate software element should be aware.



6) Indicates a point of interest or further explanation.

- Under no circumstances will Mitsubishi Electric be liable for any consequential damage that may arise as a result of the installation or use of this equipment.
- All examples and diagrams shown in this manual are intended only as an aid to understanding the text, not to guarantee operation. Mitsubishi Electric will accept no responsibility for actual use of the product based on these illustrative examples.
- Owing to the very great variety in possible application of this equipment, you must satisfy yourself as to its suitability for your specific application.

# Table of Contents

Guideline .....	ii
1. Introduction.....	1-1
1.1 Model Name .....	1-4
1.2 World Specification .....	1-5
1.3 Serial Numbers .....	1-5
1.4 Configuration .....	1-6
1.4.1 Unit Accessories.....	1-7
1.4.2 Limits of Expansion .....	1-8
1.5 Backup Data .....	1-9
1.5.1 Data Backup.....	1-9
1.5.2 Capacitor backup .....	1-9
2. Terminal Layouts .....	2-1
2.1 FX1S-**MR-ES/UL .....	2-1
2.2 FX1S-**MR-DS .....	2-2
2.3 FX1S-**MT-DSS.....	2-3
2.4 FX1S-**MT-ESS/UL .....	2-4



3. Installation Notes .....	3-1
3.1 Product Outline .....	3-2
3.2 FX1s RUN/STOP Control .....	3-3
3.3 General Specifications.....	3-4
3.4 PLC Mounting Arrangements .....	3-5
3.5 DIN Rail Mounting .....	3-6
3.6 Termination of Screw Terminals.....	3-6
3.7 Installing Optional Units.....	3-7
3.7.1 Special Function Boards .....	3-7
3.7.2 FX1N-5DM Display Module.....	3-8
4. Power Supply .....	4-1
4.1 Wiring Techniques.....	4-1
4.2 Wiring Cautions .....	4-1
4.3 Power Supply .....	4-1
4.4 Power Supply Characteristics.....	4-2
4.5 Power Supply Input Wiring .....	4-3
4.6 Earthing / Grounding .....	4-5

5. Inputs.....	5-1
5.1 24V DC Input Specifications.....	5-1
5.2 Wiring Diagrams.....	5-2
5.2.1 Input Wiring.....	5-2
5.2.2 Input Circuit Connection.....	5-3
5.2.3 Diodes and Inputs Connected in Series.....	5-3
5.2.4 Resistors and Inputs Connected in Parallel.....	5-4
6. Outputs.....	6-1
6.1 Relay Output Example.....	6-2
6.2 Reliability Tests.....	6-3
6.3 Response Times.....	6-4
6.4 Transistor Output Examples.....	6-5
6.5 Applying Safe Loads.....	6-6

7. Diagnostics .....	7-1
7.1 Preliminary Checks .....	7-1
7.2 ERROR LED ON (CPU ERROR) .....	7-2
7.3 Common Errors .....	7-3
7.4 Maintenance .....	7-3
7.5 Operation and Error Flags .....	7-4
7.6 PLC Status Registers .....	7-5
7.7 Error Registers .....	7-6
7.8 Error Codes .....	7-7
7.9 Instruction List .....	7-8
7.10 Device List .....	7-11

<b>1</b>	<b>INTRODUCTION</b>
<b>2</b>	<b>TERMINAL LAYOUTS</b>
<b>3</b>	<b>INSTALLATION NOTES</b>
<b>4</b>	<b>POWER SUPPLY</b>
<b>5</b>	<b>INPUTS</b>
<b>6</b>	<b>OUTPUTS</b>
<b>7</b>	<b>DIAGNOSTICS</b>



## 1. Introduction

This manual covers the hardware installation instructions for the FX1s Series Programmable Logic Controller.

**Table 1.1: AC Power, Relay Output Units**

MODEL	INPUT		OUTPUT		POWER SUPPLY	DIMENSIONS mm (inches)			MASS (WEIGHT) kg (lbs)
	QTY	TYPE	QTY	TYPE					
FX1S-10MR-ES/UL	6	24V DC Sink / Source	4	Relay	85 - 264 VAC	60 (2.4)	90 (3.5)	75 (3.0)	0.30 (0.66)
FX1S-14MR-ES/UL	8		6			0.40 (0.88)			
FX1S-20MR-ES/UL	12		8			0.45 (0.99)			
FX1S-30MR-ES/UL	16		14						

**Table 1.2: DC Power, Relay Output Units**

MODEL	INPUT		OUTPUT		POWER SUPPLY	DIMENSIONS mm (inches)			MASS (WEIGHT) kg (lbs)
	QTY	TYPE	QTY	TYPE					
FX1S-10MR-DS	6	24V DC Sink / Source	4	Relay	24 VDC +10, -15%	60 (2.4)	90 (3.5)	49 (1.9)	0.22 (0.48)
FX1S-14MR-DS	8		6			0.30 (0.66)			
FX1S-20MR-DS	12		8			0.35 (0.77)			
FX1S-30MR-DS	16		14						

**Table 1.3: DC Power Transistor Output Units**

MODEL	INPUT		OUTPUT		POWER SUPPLY	DIMENSIONS mm (inches)			MASS (WEIGHT) kg (lbs)
	QTY	TYPE	QTY	TYPE					
FX1S-10MT-DSS	6	24V DC Sink / Source	4	Transistor (Source)	24 VDC +10, -15%	60 (2.4)	90 (3.5)	49 (1.9)	0.22 (0.48)
FX1S-14MT-DSS	8		6			0.30 (0.66)			
FX1S-20MT-DSS	12		8			0.35 (0.77)			
FX1S-30MT-DSS	16		14						

**Table 1.4: AC Power Transistor Output Units**

MODEL	INPUT		OUTPUT		POWER SUPPLY	DIMENSIONS mm (inches)			MASS (WEIGHT) kg (lbs)
	QTY	TYPE	QTY	TYPE					
FX1S-10MT-ESS/UL	6	24V DC Sink / Source	4	Transistor (Source)	85 - 264 VAC	60 (2.4)	90 (3.5)	75 (3.0)	0.3 (0.66)
FX1S-14MT-ESS/UL	8		6			0.4 (0.88)			
FX1S-20MT-ESS/UL	12		8			0.45 (0.99)			
FX1S-30MT-ESS-UL	16		14						

**Figure 1.1: FX1s Outline Drawing**

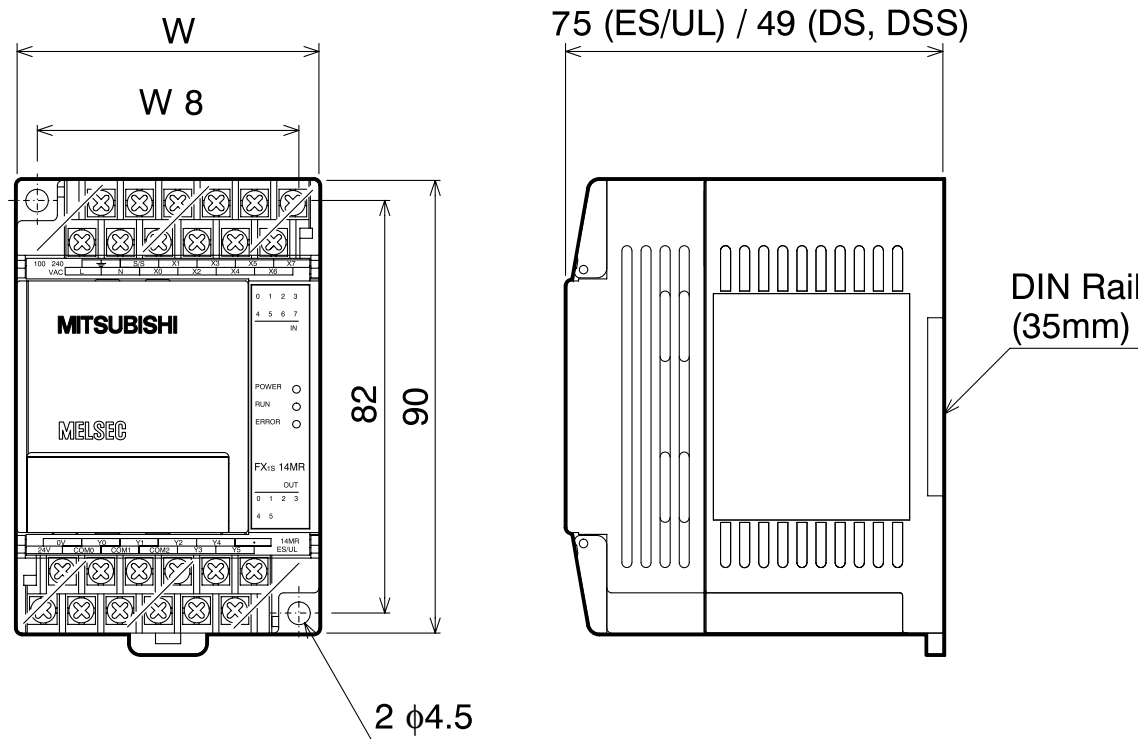

The distance between the vertical centerlines is 8mm (0.31") less than the width of the unit. Please see previous page for each model's width measurement.





## 1.2 World Specification

**Table 1.6: World / Japanese Specifications**

<b>Input Sink / Source</b>	World spec models : SINK / SOURCE Japanese models : ALWAYS SINK
<b>Outputs Transistor</b>	World spec models : ALWAYS SOURCE Japanese models : ALWAYS SINK

## 1.3 Serial Numbers

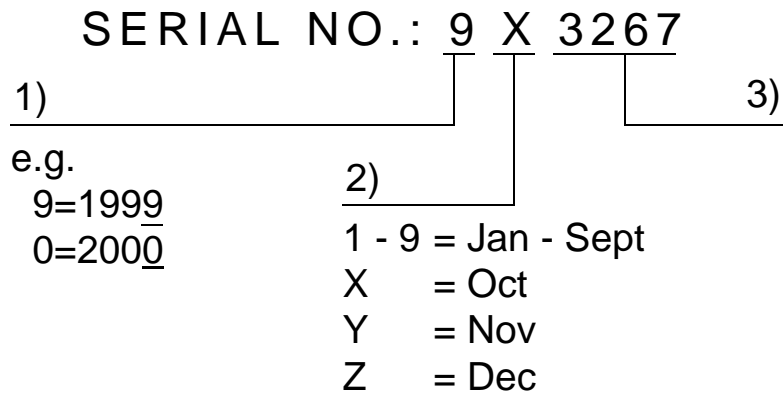
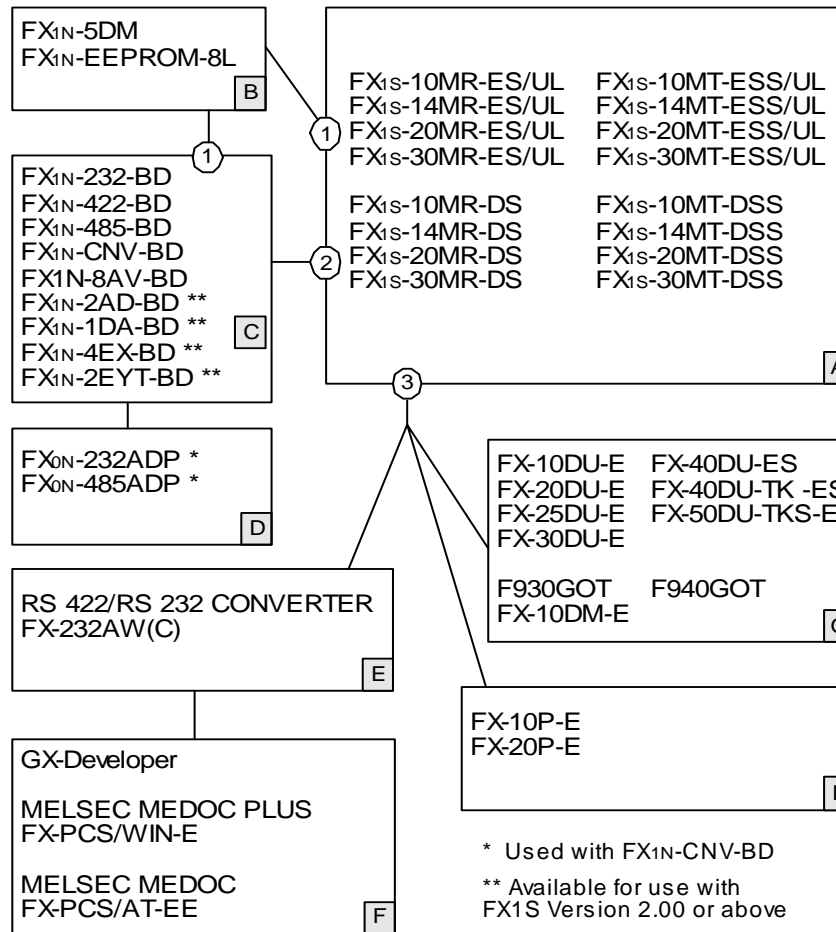

**Table 1.7: Notes on Serial Numbers**

1)	Production year
2)	Production month
3)	Production serial number

## 1.4 Configuration

Figure 1.2: Schematic System



Note: The FX1S can use one unit or communication board per square B or C, and G. To use equipment from square B and C - install module, use as required, remove and install next module.

### 1.4.1 Unit Accessories

**Table 1.8: Configuration Notes**

A	FX1s Controller Main Body
B	FX1N Memory Cassette or Display Unit
C	FX1N Expansion Boards
D	FX0N Network Adaptors
E	Programming Cables
F	Programming Software
G	HMI Devices, F900 GOT and FX-DU Series
H	Dedicated Programming Tools

**Table 1.9: Connection Ports**

1	Memory Port
2	Extension Board Port
3	Programming Port

### 1.4.2 Limits of Expansion

The following conditions cannot be accomplished the FX1S Series PLC:

- The use of Special Function Blocks.
- Supply a 5V DC service supply.
- Use FX<sub>1N</sub>-422-BD + FX-2PIF.
- Use the FX<sub>1N</sub>-5DM and the FX-10DM concurrently.
- Use more than one FX-10DM at the same time. For example, the configuration FX-10DM + (FX<sub>1N</sub>-422-BD + FX-10DM) is not allowed.

## 1.5 Backup Data

### 1.5.1 Data Backup

Data includes the Program, Comment, File Register (D1000 ~ D2499), and parameter data. This will be stored as long as the EEPROM is not damaged.

If the PLC has been powered up for five minutes or more, the following data will be saved in the EEPROM at powerdown:

S10~S127, M384 ~ M511, C16 ~ C31, T63, and D128 ~ D255.

If the PLC is powered On for less than 5 minutes, the above data is not saved!

### 1.5.2 Capacitor backup

Only the RTC is backed up by the capacitor.

The capacitor backed memory will retain data for 10 days and the capacitor requires 30 minutes to recharge upon powerup.



<b>1</b>	<b>INTRODUCTION</b>
<b>2</b>	<b>TERMINAL LAYOUTS</b>
<b>3</b>	<b>INSTALLATION NOTES</b>
<b>4</b>	<b>POWER SUPPLY</b>
<b>5</b>	<b>INPUTS</b>
<b>6</b>	<b>OUTPUTS</b>
<b>7</b>	<b>DIAGNOSTICS</b>





## 2. Terminal Layouts

The following selection of terminal layouts are taken from the FX1s product range.

Note: All layouts are diagrammatic only and are intended to aid the creation of wiring diagrams.

### 2.1 FX1s-\*\*MR-ES/UL

**Figure 2.1: Terminal Layouts, Relay Outputs, AC Power**

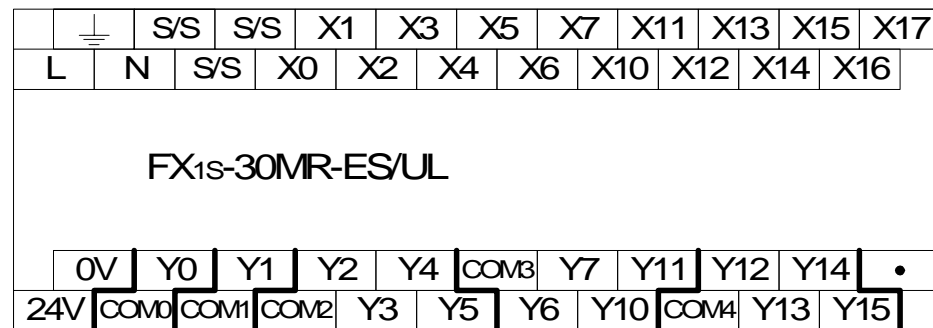
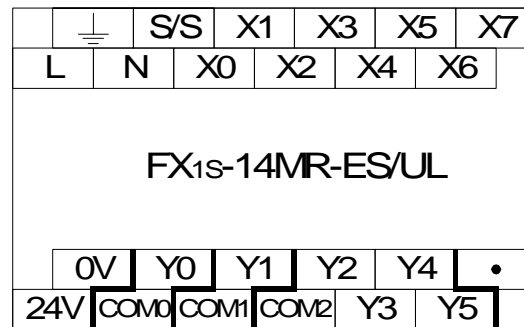
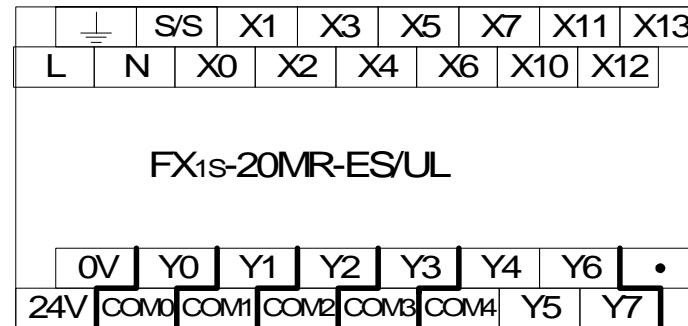
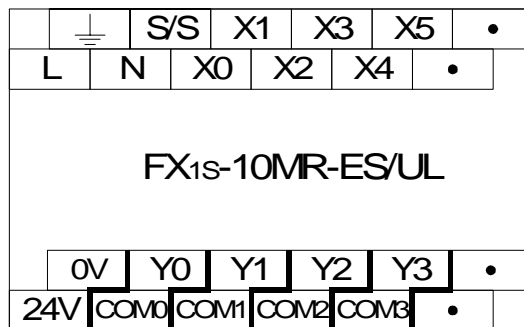

## 2.2 FX1s-\*\*MR-DS

Figure 2.2: Terminal Layouts, Relay Outputs, DC Power

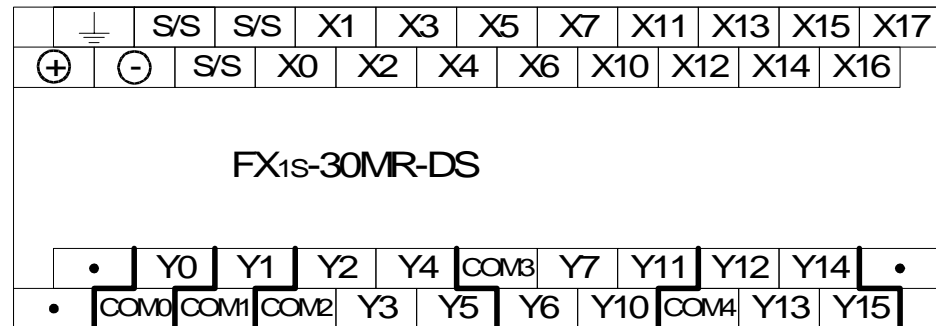
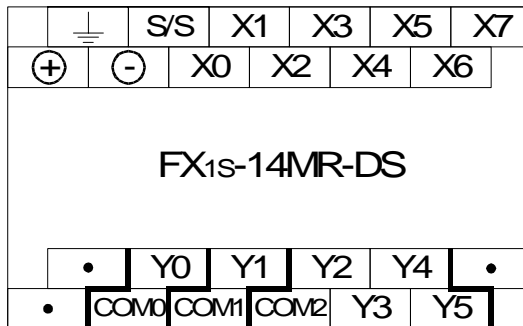
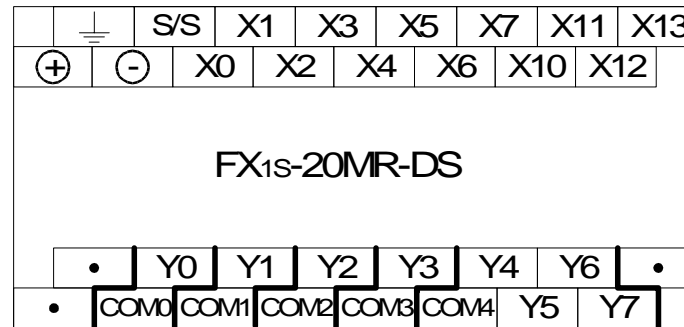
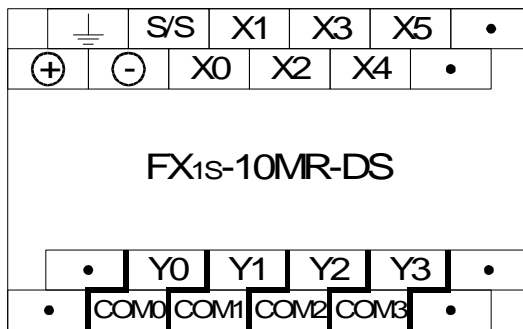

### 2.3 FX1s-\*\*MT-DSS

Figure 2.3: Terminal Layouts, Transistor Outputs, DC Power

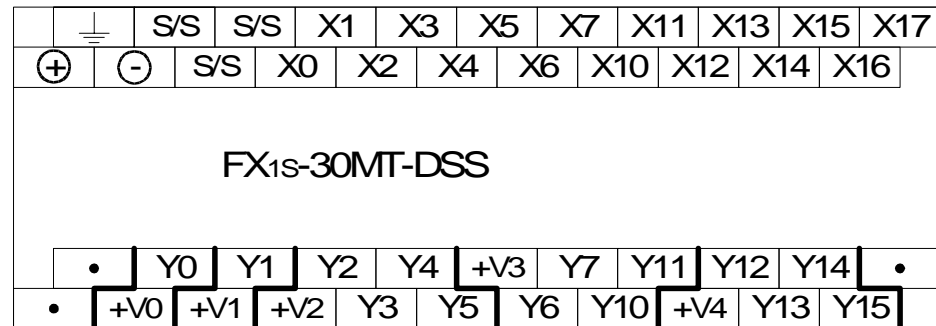
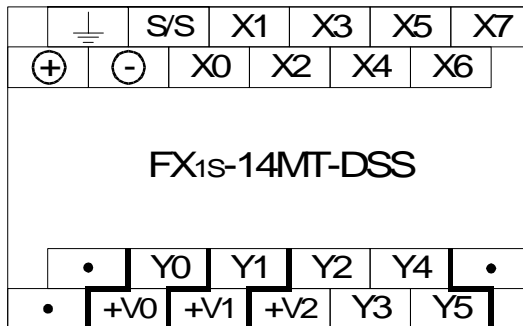
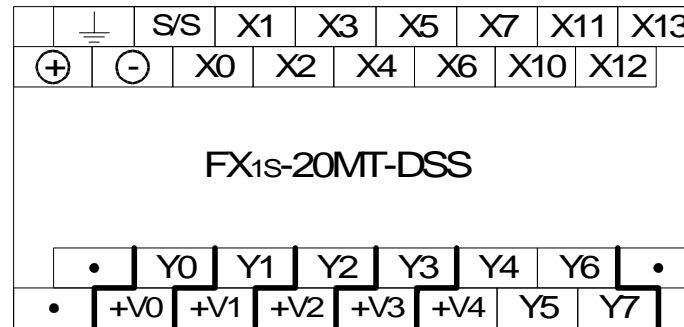
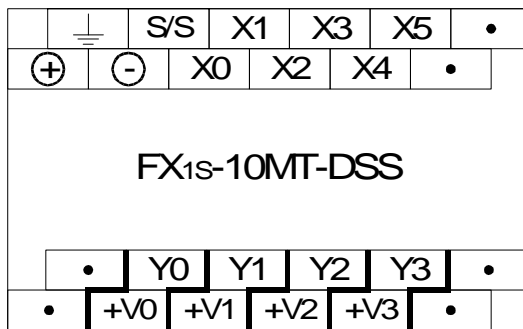

## 2.4 FX1S-\*\*MT-ESS/UL

Figure 2.4: Terminal Layouts, Transistor Outputs, AC Power

	⏏	S/S	X1	X3	X5	•
L	N	X0	X2	X4	•	
FX1s-10MT-ESS/UL						
0V	Y0	Y1	Y2	Y3	•	
24V	+V0	+V1	+V2	+V3	•	

	⏏	S/S	X1	X3	X5	X7	X11	X13
L	N	X0	X2	X4	X6	X10	X12	
FX1s-20MT-ESS/UL								
0V	Y0	Y1	Y2	Y3	Y4	Y6	•	
24V	+V0	+V1	+V2	+V3	+V4	Y5	Y7	

	⏏	S/S	X1	X3	X5	X7
L	N	X0	X2	X4	X6	
FX1s-14MT-ESS/UL						
0V	Y0	Y1	Y2	Y4	•	
24V	+V0	+V1	+V2	Y3	Y5	

	⏏	S/S	S/S	X1	X3	X5	X7	X11	X13	X15	X17
L	N	S/S	X0	X2	X4	X6	X10	X12	X14	X16	
FX1s-30MT-ESS/UL											
0V	Y0	Y1	Y2	Y4	+V3	Y7	Y11	Y12	Y14	•	
24V	+V0	+V1	+V2	Y3	Y5	Y6	Y10	+V4	Y13	Y15	

<b>1</b>	<b>INTRODUCTION</b>
<b>2</b>	<b>TERMINAL LAYOUTS</b>
<b>3</b>	<b>INSTALLATION NOTES</b>
<b>4</b>	<b>POWER SUPPLY</b>
<b>5</b>	<b>INPUTS</b>
<b>6</b>	<b>OUTPUTS</b>
<b>7</b>	<b>DIAGNOSTICS</b>



### **3. Installation Notes**

The installation of FX1S products has been designed to be safe and easy. When the products associated with this manual are used as a system or individually, they must be installed in a suitable enclosure. The enclosure should be selected and installed in accordance to the local and national standards.



### 3.1 Product Outline

Figure 3.1: Features of the FX1s PLC

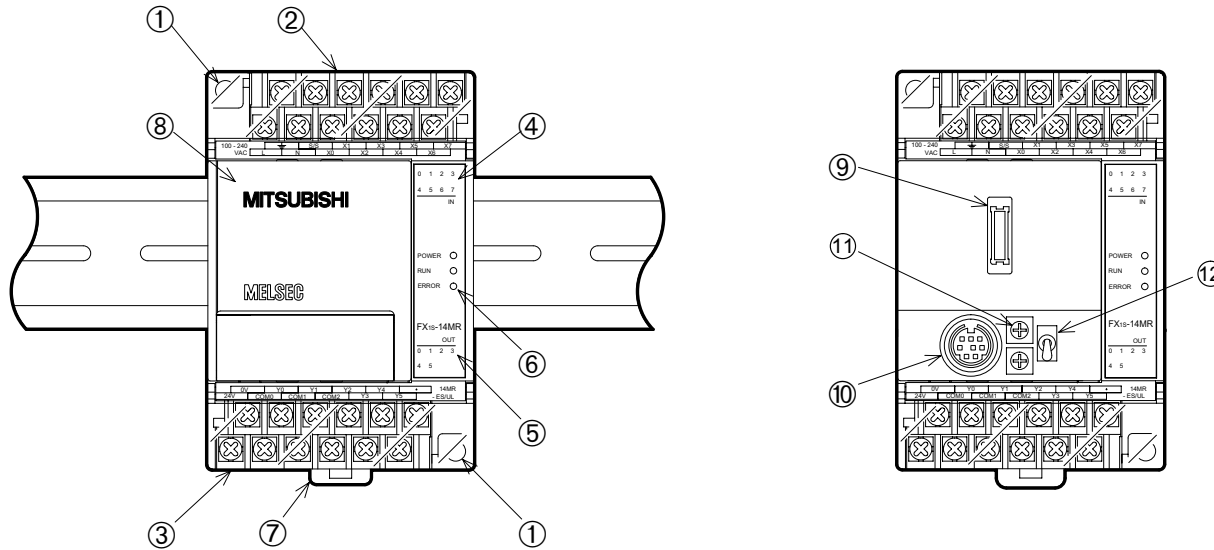

Table 3.1: Feature Table

1	Direct Mounting Holes (4.5 mm Diameter)	7	DIN Rail Mounting Clip
2	Input Terminals (24V DC) and Power Supply Terminals	8	Top Cover
3	Output Terminals and Power Supply Source Terminals	9	Optional Equipment port - Memory Cassette, FX1N-232, 422, 485, 8AV, and CNV BDs, FX1N-5DM
4	Input LED Status Indicators	10	Programming Port
5	Output LED Status Indicators	11	Analog Trim Pots. D8030 read from VR1, the top trim pot. D8031 read from VR2, the bottom trim pot.
6	PLC Status Indicators (POWER, RUN, ERROR)	12	Run/Stop Switch

### 3.2 FX1s RUN/STOP Control

RUN or STOP of the FX1s can be controlled by:

- ❶ The RUN/STOP switch mounted next to the programming port.
- ❷ A standard input (X0 to X17) defined by the system parameters.
- ❸ Remotely from a personal computer or other programming peripheral.



**Note:** The FX1s RUN/STOP switch works in parallel with the RUN input terminal. Please refer to Table 3.2.

During remote operation the FX1s RUN/STOP status is determined by the most recently operated control.

E.g. If the RUN/STOP switch is in RUN and a remote STOP is made from a personal computer, the PLC can only be restarted with the RUN/STOP switch by first moving the switch to STOP and then back to RUN.

**Figure 3.2: RUN/STOP Input Wiring Diagram**

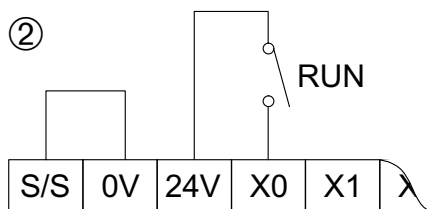

**Table 3.2: Run Status Table**

❶ RUN/STOP SWITCH	❷ RUN INPUT TERMINAL	FX1s MPU STATUS
✓	✓	RUN
✓	x	RUN
x	x	STOP
x	✓	RUN

### 3.3 General Specifications

**Table 3.3: General Specifications**

Item	Description
Operating Temperature	0 to 55 °C (32 to 131 °F)
Storage Temperature	-20 to 70 °C (-4 to 158 °F)
Operating Humidity	35 to 85% Relative Humidity, No condensation
Storage Humidity	35 to 90% Relative Humidity, No condensation
Vibration Resistance - Direct Mounting	Conforms to IEC 68-2-6; 10 - 57 Hz: 0.075 mm Half Amplitude 57 - 150 Hz: 9.8 m/s <sup>2</sup> Acceleration Sweep Count for X, Y, Z: 10 times (80 min in each direction)
Vibration Resistance - DIN Rail Mounting	Conforms to IEC 68-2-6; 10 - 57 Hz: 0.035 mm Half Amplitude 57 - 150 Hz: 4.9 m/s <sup>2</sup> Acceleration Sweep Count for X, Y, Z: 10 times (80 min in each direction)
Shock Resistance	Conforms to IEC 68-2-27: 147m/s <sup>2</sup> Acceleration, Action Time: 11 ms 3 times in each direction X, Y, and Z
Noise Immunity	1000 Vp-p, 1microsecond, 30 - 100 Hz, tested by noise simulator
Dielectric Withstand Voltage	AC Power Supply Unit: 1500 VAC > 1 min, tested between all points, terminals, and ground DC Power Supply Unit: 500 VAC > 1 min, tested between all points, terminals and ground
Insulation Resistance	5 MΩ > at 500 V DC, tested between power terminals and ground
Ground	Class D (100 Ω or less)

### 3.4 PLC Mounting Arrangements

To prevent a rise in temperature, mount the units to walls. Never mount them to the floor or ceiling of an enclosure.



#### Caution

- Units should not be installed in areas subject to the following conditions: excessive or conductive dust, corrosive or flammable gas, moisture or rain, excessive heat, regular impact shocks or excessive vibration.
- Take special care not to allow debris to fall inside the unit during installation e.g. cut wires, shavings etc. Once installation is complete remove the protective paper band to prevent overheating.

**Figure 3.3: PLC Mounting Diagram**

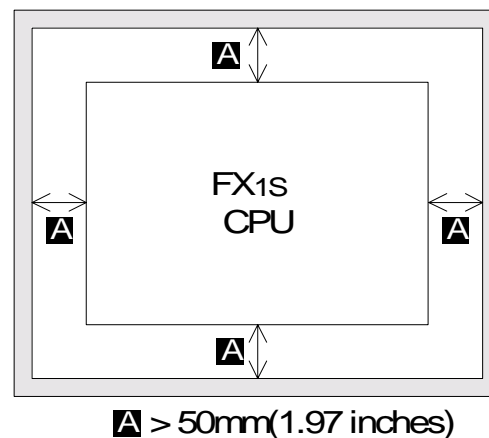

### 3.5 DIN Rail Mounting

Units can be snap mounted to 35mm DIN rail (DIN EN 50022). To release, pull the spring loaded clips away from the rail and slide the unit off and up.

### 3.6 Termination of Screw Terminals

Cables terminating at a screw terminal of an FX1S product should be fitted with insulated crimp terminals, see example shown. Terminals screws should be tightened to between 0.5 to 0.8 N·m. Screw terminals must be secured to prevent a loose connection from causing a malfunction.

**Figure 3.4: Terminal Crimp**

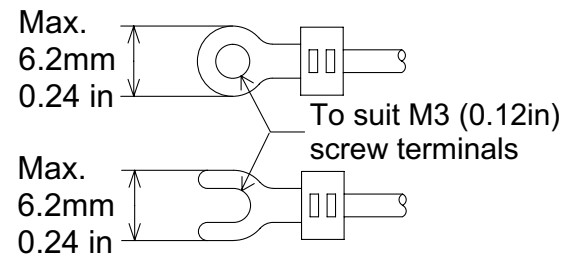

## 3.7 Installing Optional Units

### 3.7.1 Special Function Boards

The following is a generic explanation of how to install a special function board to the FX1S PLC. For greater detail and specifications of each optional unit, please see the relevant products manual.

Always make sure the power is turned off, before installing a special function board. Only one board can be used at one time, do not try to stack multiple boards.

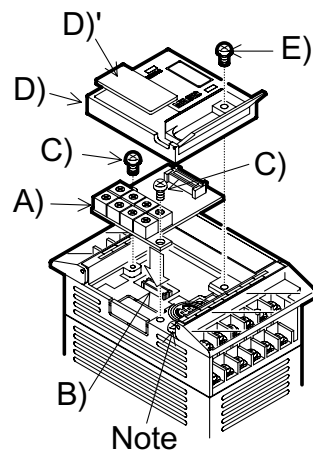

A) Special function or optional equipment board.

B) Optional equipment connector port.

C) M3 screw to secure board.

D) Top cover for board.

E) M3 screw to secure top cover.

Note: Do not remove this screw.

- Remove base unit top cover.
- Plug board A) into connector B).
- Fix board to base unit using screws C).
- Attach top cover for board D) removing section D)' to expose connector etc. (if applicable)
- Secure top cover with M3 screw E).

### 3.7.2 FX<sub>1N</sub>-5DM Display Module

Always make sure the power is turned off, before installing the 5DM.

- A) Top cover for DM
- B) Optional equipment connector.
- C) M3 screw to secure top cover.

- Remove the base unit top cover.
- Attach the top cover for DM A), and secure with screw C) (if 5DM is to be permanently mounted)
- Plug in the 5DM at connector B)

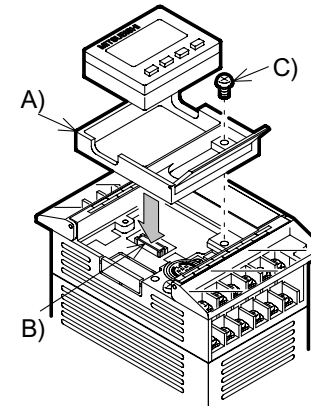

For further information please refer to the FX<sub>1N</sub>-5DM user's manual.

<b>1</b>	<b>INTRODUCTION</b>
<b>2</b>	<b>TERMINAL LAYOUTS</b>
<b>3</b>	<b>INSTALLATION NOTES</b>
<b>4</b>	<b>POWER SUPPLY</b>
<b>5</b>	<b>INPUTS</b>
<b>6</b>	<b>OUTPUTS</b>
<b>7</b>	<b>DIAGNOSTICS</b>





## 4. Power Supply

### 4.1 Wiring Techniques

The wiring of FX1S products has been designed to be safe and easy. If during the installation of these product or associated products concern is felt, please contact a professional electrician who is trained to the local and national standards applicable to the installation site.

### 4.2 Wiring Cautions



- Do not run input signals in the same multicore cable as output signals or allow them to share the same wire.
- Do not lay I/O signal cables next to power cables or allow them to share the same trunking duct. Low voltage cables should be reliably separated or insulated with regard to high voltage cabling.
- Where I/O signal lines are used over an extended distance consideration for voltage drop and noise interference should be made.

### 4.3 Power Supply



When wiring AC supplies the “Live” cable should be connected to the “L” terminal and the “Neutral” cable should be connected to the “N” terminal. Do NOT connect the “Live” wire to the “N” terminal, the user might receive a dangerous shock on powerup.

## 4.4 Power Supply Characteristics

**Table 4.1: AC Input Power Requirements, FX1S-\*\*M\*-ES/UL, ESS/UL**

Description	FX1s-10M	FX1s-14M	FX1s-20M	FX1s-30M
Power supply	100 - 240V AC, +10% -15%, 50/60 Hz			
Max. allowable momentary power failure period	10ms; if less than 10ms, the PLC will continue operation. If 10ms or more, the PLC will shut down			
Fuse (size) rating	250V 1.0A 5φ×20mm (0.2×0.79 inches)			
In-rush current	100V AC - Max. 15A for 5ms 200V AC - Max. 25A for 5ms			
Power consumption *1	19W	19W	20W	21W
24V DC Service Supply	400 mA			

\*1 Includes the input current (5 or 7mA per point).

**Table 4.2: DC Input Power Requirements, FX1S-\*\*M\*-DS, DSS**

Description	FX1s-10M	FX1s-14M	FX1s-20M	FX1s-30M
Power supply	24 V DC +10% -15%			
Max. allowable momentary power failure period	5 ms; if less than 5 ms, the PLC will continue operation. If 5 ms or more, the PLC will shut down			
Fuse rating	0.8A			
In-rush current	15A for 0.1 ms			
Power consumption *1	6W	6.5W	7W	8W

### 4.5 Power Supply Input Wiring

Figure 4.1: AC Input Example Wiring

FX1s Series

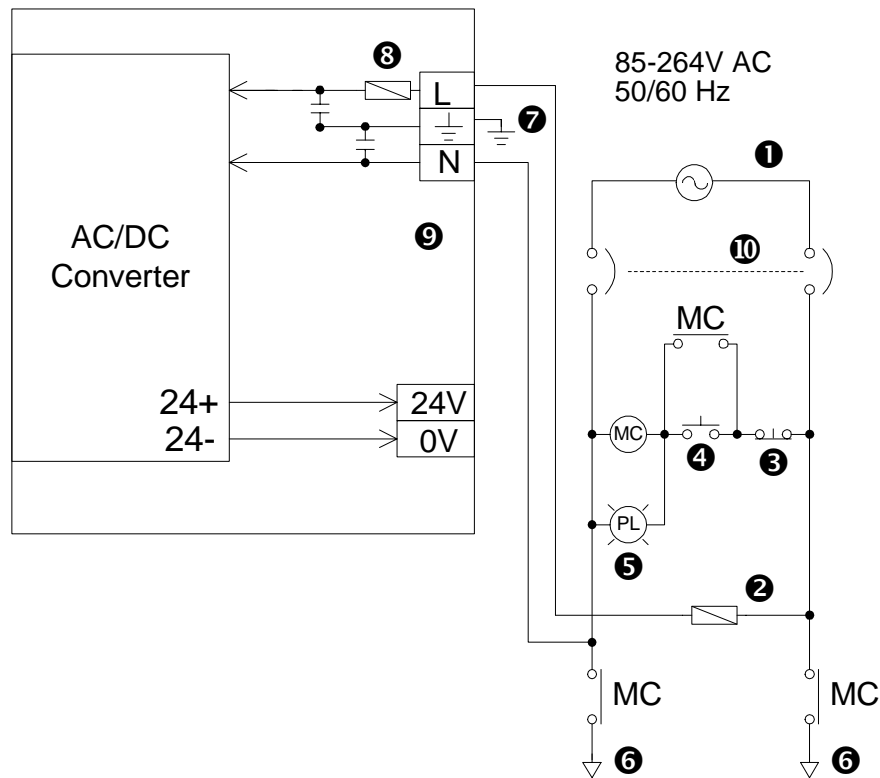

①	Power supply 100 - 240V AC, +10% -15%, 50/60 Hz
②	Circuit protector or Fuse
③	Emergency stop
④	Power supply switch
⑤	Power ON pilot indicator
⑥	Power supply for loads
⑦	Grounding resistor 100Ω or less (class D)
⑧	Fuse
⑨	Main unit
⑩	Breaker

Figure 4.2: DC Input Example Wiring

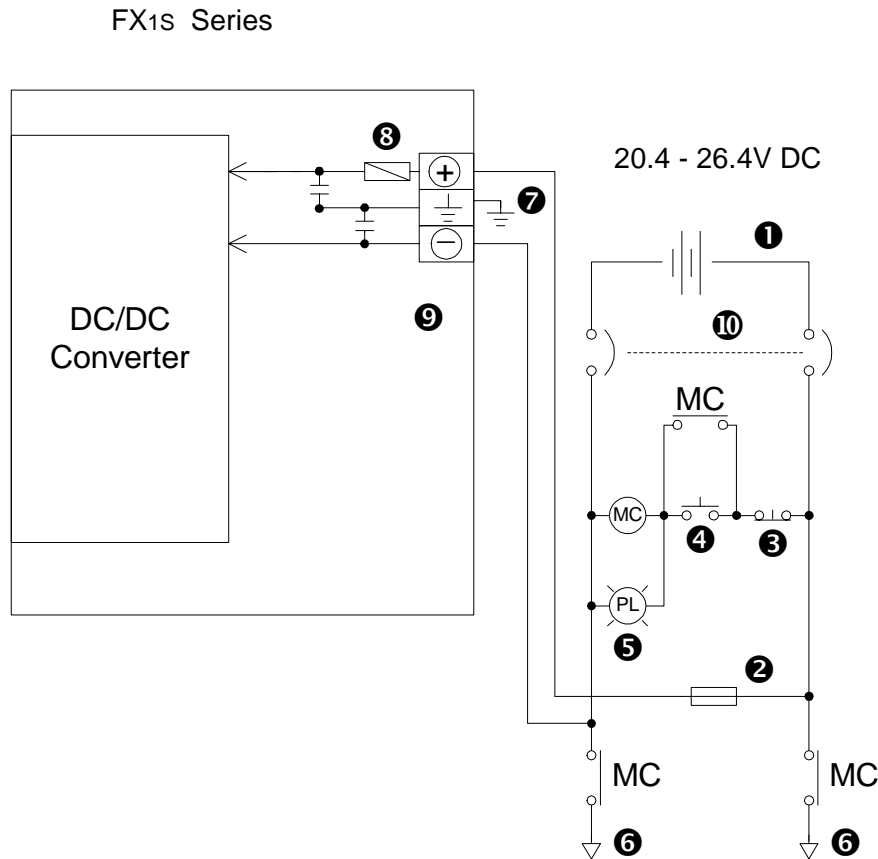

①	Power supply 24V DC, +10% -15%
②	Circuit protector or Fuse
③	Emergency stop
④	Power supply switch
⑤	Power ON pilot indicator
⑥	Power supply for loads
⑦	Grounding resistor 100Ω or less (class D)
⑧	Fuse
⑨	Main unit
⑩	Breaker

## 4.6 Earthing / Grounding



Use a cable at least 0.2mm<sup>2</sup> (AWG24) to ground equipment. Ground resistance must be less than 100Ω (class D). Note that the ground cable must not be connected to the same ground as the power circuits. Grounding is recommended but if a proper ground cannot be provided the PLC will still operate correctly without being grounded.



<b>1</b>	<b>INTRODUCTION</b>
<b>2</b>	<b>TERMINAL LAYOUTS</b>
<b>3</b>	<b>INSTALLATION NOTES</b>
<b>4</b>	<b>POWER SUPPLY</b>
<b>5</b>	<b>INPUTS</b>
<b>6</b>	<b>OUTPUTS</b>
<b>7</b>	<b>DIAGNOSTICS</b>





## 5. Inputs

### 5.1 24V DC Input Specifications

**Table 5.1: FX1s Input Specifications**

		FX1s Main Unit	
		X0 - X7	X10 - X17
Input voltage		24V DC +/- 10%	
Input current		24V DC, 7mA	24V DC, 5mA
Input switching current	OFF → ON	>4.5mA	>3.5mA
	ON → OFF	<1.5mA	
Response time		10ms (default)	
Variable response time		0 - 15ms for X000-X017 via use of the FX1s digital filter.	
Circuit isolation		Photocoupler	
Operation indication		LED is lit	

## 5.2 Wiring Diagrams

### 5.2.1 Input Wiring

**Figure 5.1: Input Wiring Diagrams**

FX1s-Source

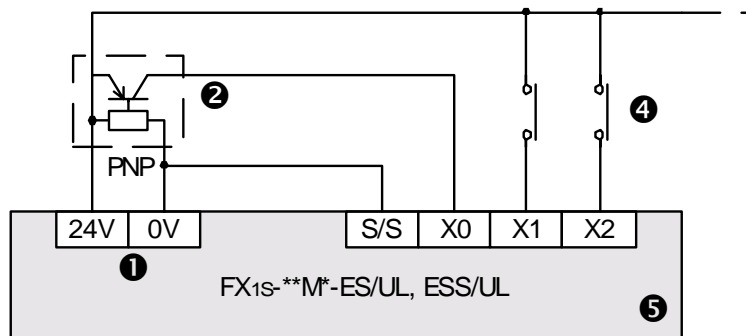

FX1s-Sink

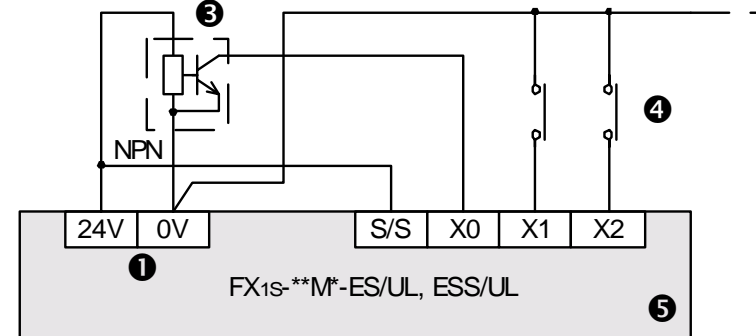

1	24V DC Service Supply
2	PNP Sensor
3	NPN Sensor
4	Input Device Contact
5	FX1s Controller Main Body

### 5.2.2 Input Circuit Connection

**Figure 5.2: Input Circuit Diagrams (Source/Sink)**



### 5.2.3 Diodes and Inputs Connected in Series

**Figure 5.3: Diode Connection Diagram**

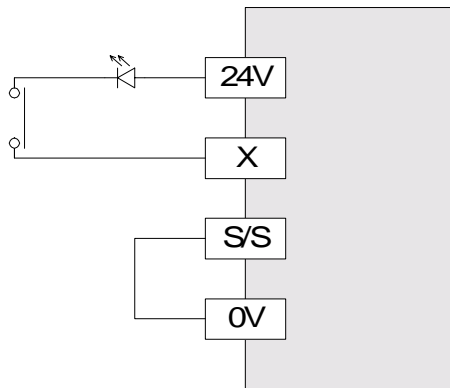

Voltage drop across the diode is Max. 4V.  
 No more than 2 LEDs should be connected in series.

### 5.2.4 Resistors and Inputs Connected in Parallel

Parallel resistance  $R_p$ :  $FX_{1S} = 15k\Omega$ . If resistance  $R_p$  is less than the stated value, then add the  $R_b$  value using the Equation 1 calculation.

Alternatively; Current leakage:  $FX_{1S} = 1.5mA$ . If the current leakage is greater than the stated value, then add the  $R_b$  value using the equation 2 calculation.

**Figure 5.4: Parallel LED Diagram**

$$\text{Eqn 1: } R_b \leq \frac{4R_p}{15 - R_p}$$

$$\text{Eqn 2: } R_b \leq \frac{6}{I - 1.5}$$

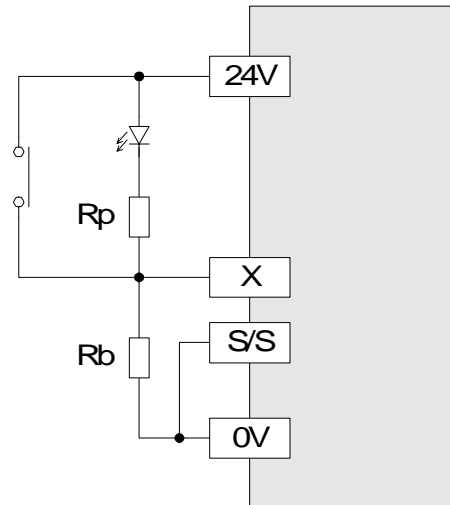

<b>1</b>	<b>INTRODUCTION</b>
<b>2</b>	<b>TERMINAL LAYOUTS</b>
<b>3</b>	<b>INSTALLATION NOTES</b>
<b>4</b>	<b>POWER SUPPLY</b>
<b>5</b>	<b>INPUTS</b>
<b>6</b>	<b>OUTPUTS</b>
<b>7</b>	<b>DIAGNOSTICS</b>



## 6. Outputs

**Table 6.1: Output Specifications**

Description		Relay Output	Transistor Output
Switched voltages (resistive load)		$\leq 240\text{V AC}, \leq 30\text{V DC}$	5 - 30V DC
Rated current / N points (resistive load)		2A/1 point, 8A/COM	0.5A/1 point, 0.8A/COM
Max. Inductive load		80VA, 120/240 VAC, See table 6.2 for more details	12W/24V DC
Max. Lamp load (tungsten load)		100W (1.17A/85V AC, 0.4A/250V AC)	0.9W/24V DC
Minimum load		When supply voltage < 5V DC allow at least 2mA flow	-----
Response time (approx.)	OFF → ON	10ms	< 0.2ms; <5 $\mu\text{s}$ (Y0,Y1 only)
	ON → OFF	10ms	< 0.2ms (I > 0.2 A); <5 $\mu\text{s}$ (Y0,Y1 only)
Circuit isolation		By Relay	PhotoCoupler
Open circuit current leakage		-----	0.1mA/30V DC
Operation indication		LED is lit when coil is energized	



### 6.1 Relay Output Example

Figure 6.1: Typical Relay Wiring Diagram

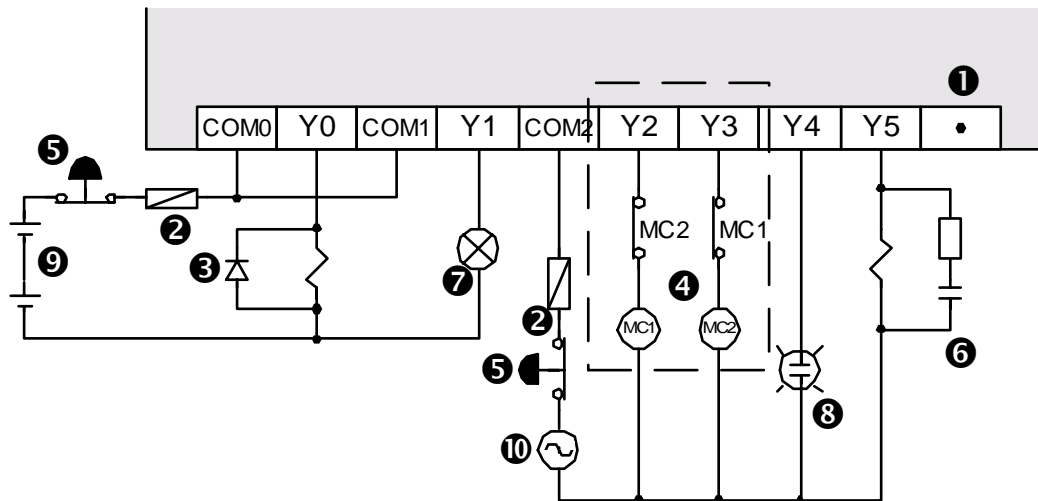

①	Do not use this terminal
②	Fuse
③	Surge absorbing Diode
④	External Mechanical Interlock
⑤	Emergency Stop
⑥	Noise suppressor 0.1μF capacitor + 100-120Ω resistor
⑦	Valve
⑧	Incandescent Lamp
⑨	DC Power Supply
⑩	AC Power Supply

## 6.2 Reliability Tests



The test results in Table 6.2 were gathered from a 1 sec ON/OFF test cycle. Please note that the over current induced by in-rush greatly reduces the relay contacts service life. The rated life for an inductive AC load such as a contactor or solenoid valve is 500,000 operations at 20VA.

**Table 6.2: Relay Life Cycle Data**

Description	20VA	35VA	80VA
Load capacity	0.2A/100VAC 0.1A/200VAC	0.35A/100V AC 0.17A/240V AC	0.8A/100V AC 0.4A/240V AC
Life of contact (cycles)	3,000,000	1,000,000	200,000
Example load (Mitsubishi contactor)	S-K10 ~ S-K95	S-K100 ~ S-K150	S-K180,S-K400

### 6.3 Response Times

OFF times increase as the load current decreases.

For improved response times use a 'dummy' resistor, see Figure 6.2. If a response time of 0.5 ms or better is required when using 'light loads' use a 'dummy' resistor and ensure the signal line has a current greater than 60mA/24V DC.

**Figure 6.2: Dummy load**

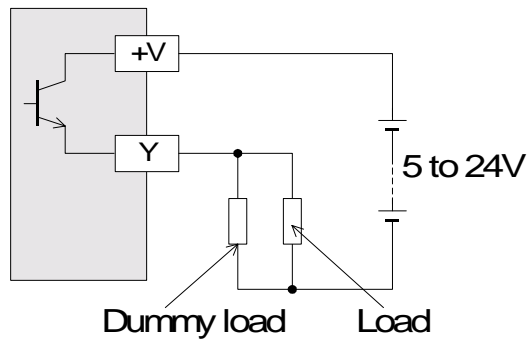

Y000 and Y001 are high speed response outputs with the following characteristics:  
10 - 100 mA at 5 - 24V DC, 100 kHz maximum output signal.

If the high speed response is required, a current of 10 - 100mA must be used.

### 6.4 Transistor Output Examples

Figure 6.3: Transistor Output Wiring Diagram

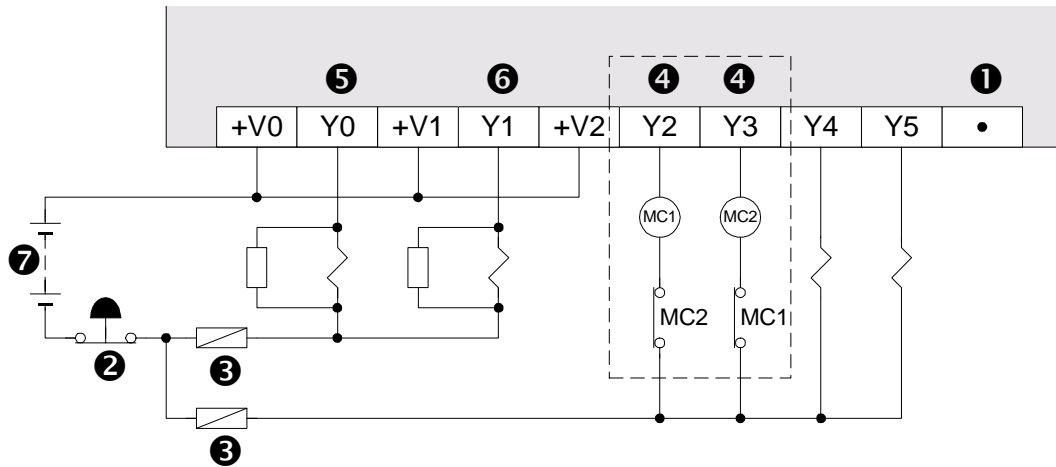

①	Do not use this terminal
②	Emergency Stop
③	Fuse
④	External Mechanical Interlock
⑤	Output Terminal Y0
⑥	Output Terminal Y1
⑦	DC Power Supply

Figure 6.4: Japanese Model Transistor Output

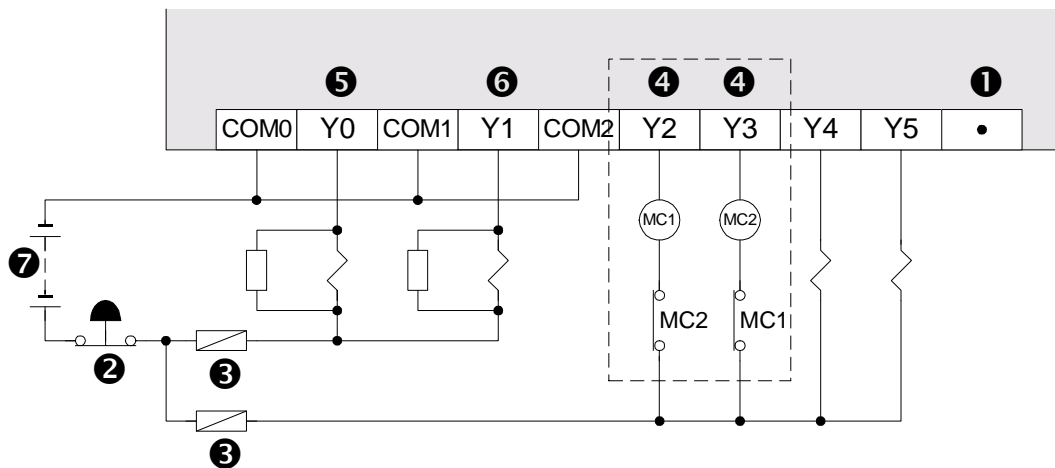

## 6.5 Applying Safe Loads



Ensure all loads are applied to the same side of each PLC output, see previous figures. Loads which should NEVER simultaneously operate (e.g. direction control of a motor), because of a safety critical situation, should not rely on the PLC's sequencing alone. Mechanical interlocks MUST be fitted to all safety critical circuits, see previous figures.

<b>1</b>	<b>INTRODUCTION</b>
<b>2</b>	<b>TERMINAL LAYOUTS</b>
<b>3</b>	<b>INSTALLATION NOTES</b>
<b>4</b>	<b>POWER SUPPLY</b>
<b>5</b>	<b>INPUTS</b>
<b>6</b>	<b>OUTPUTS</b>
<b>7</b>	<b>DIAGNOSTICS</b>



## 7. Diagnostics

### 7.1 Preliminary Checks

**Table 7.1: Preliminary Checks**

<p>POWER <input type="checkbox"/>                  RUN <input type="checkbox"/>                  ERROR <input type="checkbox"/></p>	<p>Check power supply, ground and I/O cables are wired correctly.</p>
<p>POWER <input checked="" type="checkbox"/>                  RUN <input type="checkbox"/>                  ERROR <input type="checkbox"/></p>	<p>Turn the power supply on. Check the power LED is lit. Down load a small test program into the PLC. Verify the program to ensure it has been written to the PLC correctly. Using the programming device forcibly turn ON/OFF each output. Check the output LEDs for operation.</p>
<p>POWER <input checked="" type="checkbox"/>                  RUN <input checked="" type="checkbox"/>                  ERROR <input type="checkbox"/></p>	<p>Put the PLC into RUN. Check the RUN LED is lit. Check the previously down loaded program works correctly. Once all checks are complete take the PLC out of run and turn OFF the power supply.</p>
	<p>During this testing stage take extreme care not to touch any live or hazardous parts.</p>



## 7.2 ERROR LED ON (CPU ERROR)

**Table 7.2: Error LED Checks**

POWER ■ RUN □ ERROR ■	<b>Fault</b> ERROR LED ON	<b>Remedy</b> Reset PLC. Turn power OFF, then ON and trigger RUN input.	<b>Possible results</b>	LED OFF	Has the memory cassette been installed or removed while the unit was still powered On?
				LED is lit	A
A	<b>Remedy</b> Power OFF Disconnect earth/ground terminal Power ON	<b>Possible results</b>	LED is lit	B	
			LED is flashing	Check for programming error. Ensure the earth/ground cable is correctly rewired. 	
B	<b>Remedy</b> Possible program/scan time error. Check D8012 for program scan time, (units 0.2 ms must be less than 0.2 sec, i.e. - data value <2000).		Possible results D8012 > D8000		

### **7.3 Common Errors**

- Corroded contact points at some point in an I/O line.
- An I/O device has been used outside its specified operating range.
- An input signal occurs in a shorter time period than that taken by one program scan.

### **7.4 Maintenance**

- Check interior temperature of the panel.
- Check panel air filters if fitted.
- Check for loosening of terminals or mounting facilities (due to vibration).

## 7.5 Operation and Error Flags

**Table 7.3: Operation and Error Flags**

<b>M8004</b> (ref. 8004)	Error occurrence (ON when M8060-7 are ON)
<b>M8035</b>	Forced RUN mode
<b>M8036</b>	Forced RUN signal
<b>M8037</b>	Forced STOP signal
<b>M8039</b> (ref. D8039)	Constant scan mode

<b>M8061</b> (ref. D8061)	PLC hardware error
<b>M8063</b> (ref. D8063)	Parallel link error
<b>M8064</b> (ref. D8064)	Parameter error
<b>M8065</b> (ref. D8065, D8069)	Syntax error
<b>M8066</b> (ref. D8066, D8069)	Program (circuit) error
<b>M8067</b> (ref. D8067, D8069)	Program execution error
<b>M8068</b> (ref. D8068)	Execution error latch

## 7.6 PLC Status Registers

**Table 7.4: PLC Status Registers**

<b>D8000</b> (default 200msec)	Watchdog timer
<b>D8001</b>	PLC version 22100 = FX1s Version 1.00 22 = FX1s, 100 = Version 1.00
<b>D8002</b>	Memory capacity 0002=2K steps
<b>D8003</b>	Memory type 02H=EEPROM protect switch OFF 0AH=EEPROM protect switch ON 10H=MPU memory
<b>D8004</b>	Error flag number 8060=M8060, (8060-8068)

## 7.7 Error Registers

**Table 7.5: Error Registers**

<b>D8061</b>	Error code for PLC hardware error
<b>D8063</b>	Error code for parallel link fault
<b>D8064</b>	Parameter error code
<b>D8065</b>	Syntax error code
<b>D8066</b>	Program (circuit) error code
<b>D8067</b>	Program execution error code
<b>D8068</b>	Latched step number of execution error
<b>D8069</b>	Step number of errors associated with error flags M8065-M8067

## 7.8 Error Codes

**Table 7.6: Error Codes**

<b>D8061</b>	Check cable connections	
	0000	No error
	6101	RAM error
	6102	Operation circuit error
	6103	I/O bus error (M8069 = ON)
<b>D8062</b>	Check the programmer / PLC connections	
	0000	No error
	6201	Parity/overrun/framing error
	6202	Character error
	6203	Data sum check error
	6204	Data format error
	6205	Command error

<b>D8063</b>	Check both power and communications connections	
	0000	No error
	6301	Parity/overrun/framing error
	6302	Character error
	6303	Data sum check error
	6304	Data format error
	6305	Command error
6306	Watchdog timer error	

## 7.9 Instruction List

**Table 7.7: Numerically Sorted**

		0	1	2	3	4	5	6	7	8	9
000	PROGRAM FLOW	CJ	CALL	SRET	IRET	EI	DI	FEND	WDT	FOR	NEXT
010	TRANSFERS, COMP	CMP	ZCP	MOV			BMOV			BCD	BIN
020	+x÷, LOGICS	ADD	SUB	MUL	DIV	INC	DEC	WAND	WOR	WXOR	
030	SHIFT					SFTR	SFTL			SFWR	SFRD
040	DATA OPERATION 1	ZRST	DECO	ENCO							
050	HIGH+SPEED	REF		MTR	HSCS	HSCR		SPD	PLSY	PWM	PLSR
060	HANDY INSTR. 1	IST		ABSD	INCD			ALT	RAMP		
070	FX I/O DEVICES			DSW		SEGL					
080	FX SER DEVICES	RS	PRUN	ASCI	HEX	CCD	VRRD	VRSC		PID	
150	POSITIONING						ABS	ZRN	PLSV	DRVI	DRVA
160	REAL TIME CLOCK	TCMP	TZCP	TADD	TSUB			TRD	TWR		HOUR
220	IN-LINE COMPARE					LD=	LD>	LD<		LD≠	LD≤
230		LD≥		AND=	AND>	AND<		AND≠	AND≤	AND≥	
240		OR=	OR>	OR<		OR≠	OR≤	OR≥			

**Table 7.8: Alphabetically sorted**

	Symbol	FNC No.	D	P
<b>A</b>	ABS	155		
	ABSD	062		
	ADD	020		
	ALT	066		
	AND□	232-238		
	ASCI	082		
<b>B</b>	BCD	018		
	BIN	019		
	BMOV	015		
<b>C</b>	CALL	001		
	CCD	084		
	CJ	000		
	CMP	010		

	Symbol	FNC No.	D	P
<b>D</b>	DEC	025		
	DECO	041		
	DI	005		
	DIV	023		
	DRVA	159		
	DRVI	158		
	DSW	072		
<b>E</b>	EI	004		
	ENCO	042		
<b>F</b>	FEND	006		
	FOR	008		

	Symbol	FNC No.	D	P
<b>H</b>	HEX	083		
	HOUR	169		
	HSCR	054		
	HSCS	053		
<b>I</b>	INC	024		
	INCD	063		
	IRET	003		
	IST	060		
<b>L</b>	LD	224-230		
<b>M</b>	MOV	012		
	MTR	052		
	MUL	022		
<b>N</b>	NEXT	009		
<b>O</b>	OR□	240-246		



	Symbol	FNC No.	D	P
<b>P</b>	PID	088		
	PLSR	059		
	PLSV	157		
	PLSY	057		
	PRUN	081		
	PWM	058		
<b>R</b>	RAMP	067		
	REF	050		
	RS	080		
<b>S</b>	SEGL	074		
	SFRD	039		
	SFTL	035		
	SFTR	034		

	Symbol	FNC No.	D	P
<b>S</b>	SFWR	038		
	SPD	056		
	SRET	002		
	SUB	021		
<b>T</b>	TADD	162		
	TCMP	160		
	TRD	166		
	TSUB	163		
	TWR	167		
	TZCP	161		

	Symbol	FNC No.	D	P
<b>V</b>	VRRD	085		
	VRSC	086		
<b>W</b>	WAND	026		
	WDT	007		
	WOR	027		
<b>Z</b>	WXOR	028		
	ZCP	011		
	ZRN	156		
	ZRST	040		

## 7.10 Device List

**Table 7.9: Device List**

Device Type		Description
Program capacity		2K steps by FX1S internal EEPROM or 2K steps by FX1N-EEPROM-8L
Input (X) relay	X0 - X17 (16 pts)	(X + Y) ≤ 30 pts Max.
Output (Y) relay	Y0 - Y15 (14 pts)	
Auxiliary relay (512 pts + 256 pts)	General Auxiliary Relays	M0-M383 (384 pts)
	Latched Relays	M384-M511 (128 pts)
	Special function	M8000-M8255 (256 pts)
State relay (128 pts)	Initial State Relay	S0-S9 (10 pts), same as latched state relay
	Latched State Relay	S10-S127 (118 pts)
Timer (64 pts)	100 ms	T0-T62 (63 pts)
	10 ms	If M8028 is On, T32 - T62 are 10ms timers (31 pts)
	1 ms	T63 (1 pt)

Device Type		Description
Counter (32 normal and 21 High Speed counters)	General Counter	C0-C15 (16 pts)
	Latched Counter	C16-C31 (16 pts)
	High Speed Counter	C235-C255
Data register (1500 pts, + 256 pts)	General Use Register	D0-D127 (128 pts)
	Latched Register	D128-D255 (128 pts)
	File Register	D1000-D2499 (1500 pts)
	Diagnostic Register	D8000-D8255 (256 pts)
	Index	V0-V7, Z0-Z7 (16 pts)
Pointers	Pointer	P0-P63 (64 pts)
	Interupt Pointer	I00□ - I50□ (6 pts)
Nest Level		N0 - N7 (8 pts)
Numbers	16 bit	32 bit
K	-32,768 to 32,767	-2,147,483,648 to 2,147,483,647
H	0 to FFFFH	0 to FFFFFFFFH



# HARDWARE MANUAL

FX1S SERIES PROGRAMMABLE CONTROLLERS



HEAD OFFICE: MITSUBISHI DENKI BLDG MARUNOUCHI TOKYO 100-8310 TELEX: J24532 CABLE MELCO TOKYO  
HIMEJI WORKS: 840, CHIYODA CHO, HIMEJI, JAPAN

---

JY992D83901E  
(MEE0106)

Effective June 2001  
Specifications are subject  
to change without notice.